

# EA15B Semi-Electric Straddle Stacker



Model		EA15B
Load Capacity	(lb.)	3300
Lifting height Max.	(in)	119.4
Load center distance	(in)	24
Fork length	(in)	45.3
Single fork width	(in)	3.9
Overall fork width	(in)	8-33.4
Lowered fork height	(in)	2.4
Fixed leg length	(in)	34
Fixed leg width, single	(in)	3.9
Adjustable legs	(in)	43.5-59.1
Turning radius	(in)	53.2
Overall length	(in)	73
Overall width max	(in)	59
Extended mast height	(in)	140.5
Lowered mast height	(in)	84.5
Battery Voltage	(V/Ah)	12V/120Ah
Charger	(V/A)	12V/15A
Lift Motor	(V/W)	DC 12V/1500W
Service Weight	(lb.)	1200

The EKKO EA15B Semi-Electric Straddle Stacker is designed with the combination of the versatility of a forklift and a pallet stacker. It is ideal for loading and unloading trucks, loading docks, stock rooms, manufacturing floors and warehousing.

Made from high quality steel and components with durable quality drives to withstand any terrain, usage, impact and directional changes for the use of any application with confidence and assurance.

- Load Capacity 3300 lb.
- Raised Height 119.4" (9.95ft)
- Adjustable Forks 8.3-33.4"
- Adjustable Legs 43.5-59.1"
- Power Lifting
- Manual Drive
- External Charger 12V/15Ah
- Battery 12V/120Ah
- Ergonomic Handle
- Steel Construction
- Robotic Welding
- 3 Year Limited Warranty

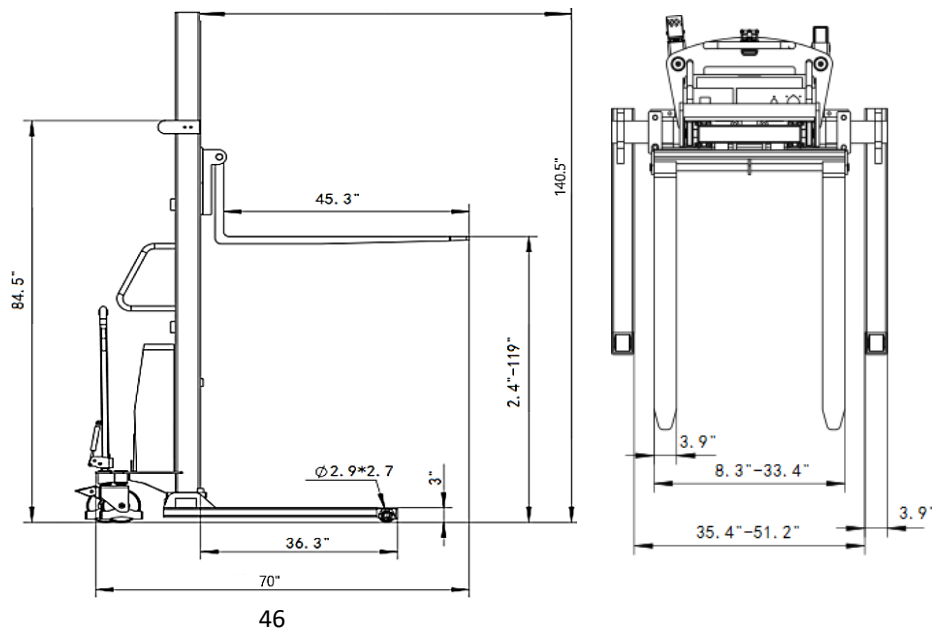

# EKKO<sup>®</sup>

MATERIAL HANDLING EQUIPMENT

**MOVING AHEAD**

## SEMI-ELECTRIC STRADDLE STACKER EA15B

- 3300 lbs. Capacity
- 119.4" lift Height
- Narrow Aisles 7 ft.
- Adjustable Legs 45.7-59.1 in.
- Adjustable Forks 8.3-33.5 in.
- Batteries and Charger Included
- 3 Year Limited Warranty



## EA15B

Superior quality, maneuverable, compact, and durable for all your material handling applications. Ideal for small aisles and areas.

**WEIGHT CAPACITY:** 3300 lbs. @ 24" load center

**LIFT HEIGHT:** 119.4" (9.95 ft.)

**FORK LENGTH:** 45.3"

**ADJUSTABLE OUTRIGGERS:** 45.7" TO 59.1"

**ADJUSTABLE FORKS:** 8.3" TO 33.5"

**MAST HEIGHT:** 84.5"

**TURNING RADIUS:** 53.2"

**INTEGRAL BATTERY / CHARGER:** 12V 120AH, deep cycle maintenance-free batteries with external direct connect 110A 110VAC plug-in automatic 24V/15A charger (both Included)

**LIFTING SPEED:** 5.35 ips empty; 3.6 ips loaded

**LOWERING SPEED:** 3.85 ips empty; 4.4 ips loaded

**DRIVE WHEELS:** 9" x 3" Nylon

**LOAD WHEELS:** (2) 4" x 3" Nylon per outrigger

**HYDRAULICS LIFTING MOTOR:** 24V 1500 Watt lifting Motor.

**BRAKES:** Foot Brake

**OPERATOR CONTROLS:** lifting, lowering, battery meter

**CHASSIS AND MAST:** Robotic Welding; Heavy duty steel chassis with I-beam mast for durability; Telescoping mast includes a protective steel guard.



# Walkie Straddle Stacker

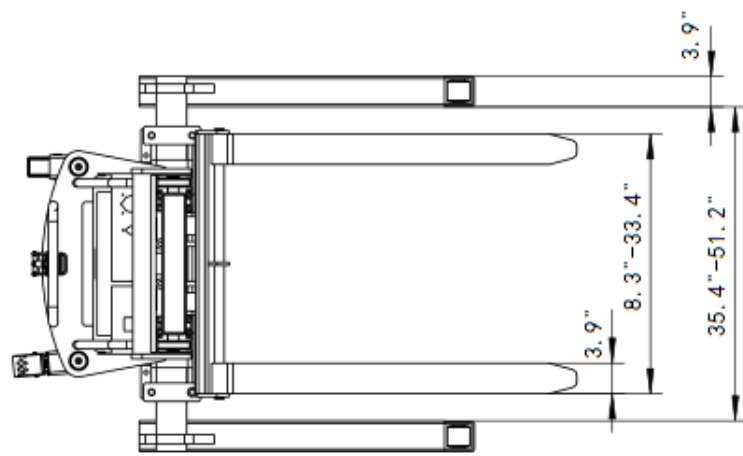
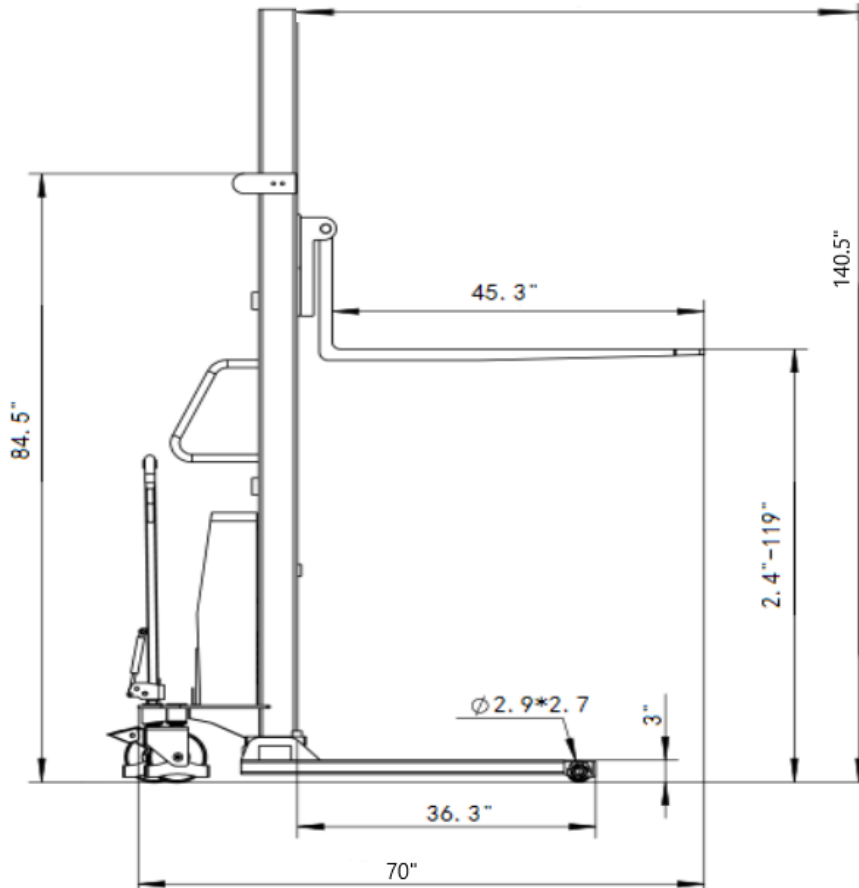

MODEL #	MAST	LIFT HEIGHT	SERVICE WEIGHT
EA15B	84.5"	119.4"	1200



1761 W. Holt Ave.  
 Pomona, CA 91768 USA  
 T: (877) 232-6517 F: (909) 222-6861

AUTHORIZED DEALERS ONLY  
[www.ekkolifts.com](http://www.ekkolifts.com)