

# EB12EA Full Powered Walkie Stacker

The EKKO EB12EA Electric Straddle Stacker is designed with the combination of the versatility of a forklift, reach truck and a walkie stacker. It is ideal for loading and unloading trucks, loading docks, stock rooms, manufacturing floors and warehousing.

Made from high quality steel and components with durable quality drives to withstand any terrain, usage, impact and directional changes for the use of any application with confidence and assurance.

- Load Capacity 3000 lb.
- Raised Height 145.67"
- Adjustable Forks 8.3-33.5"
- Adjustable Legs 45.7-59.1"
- Fork Length 45.3"
- Curtis Instrument Controller
- **24V AC Drive Motor 1500 Watt**
- 24V Lift Motor
- Battery 2\*12V/120Ah
- Polyurethane Wheels
- Ergonomic Handle and Controls
- Steel Construction
- Robotic Welding
- 3 Year Limited Warranty

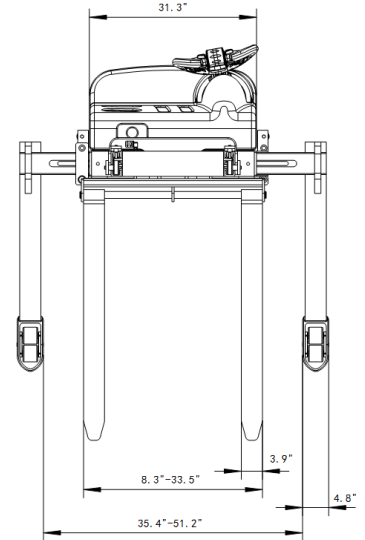
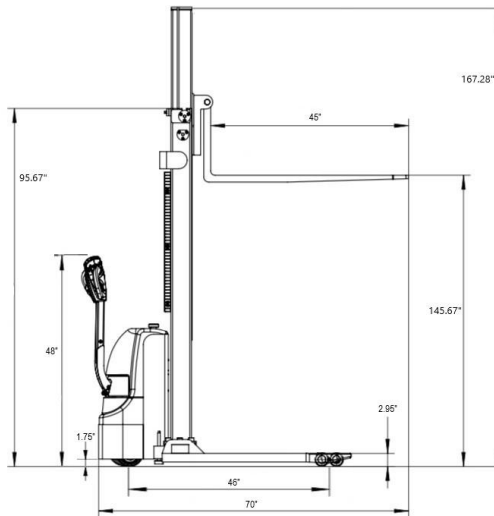

| Model                        |       | EB12EA  |
|------------------------------|-------|---|
| Load capacity                | (lb.) | 3000  |
| The max. lifting height      | (in)  | 145.67"   |
| Load center distance         | (in)  | 24  |
| Fork length                  | (in)  | 45.3  |
| Single fork width            | (in)  | 4   |
| Overall fork width           | (in)  | 8.3-33.5  |
| Lowered fork height          | (in)  | 2.35  |
| Fixed leg length             | (in)  | 36.5  |
| Adjustable legs              | (in)  | 45.5-59.1   |
| Turning radius               | (in)  | 52.6  |
| Overall length               | (in)  | 70  |
| Max Overall width            | (in)  | 61  |
| Extended mast height         | (in)  | 167.28  |
| Lowered mast height          | (in)  | 95.67   |
| Battery voltage (dimensions) | (in)  | 2 × 12V/120AH (10/6.6/8.5)  |
| Internal Charger             | (V/A) | 24V/15A   |
| Lifting Motor                | (V/W) | 2200 Watt, Lift speed, laden/unladen:92/136mm/s<br>Lowering speed, laden/unladen:112/98mm/s |
| Driving Motor                | (W)   | 1500 Watt, Driving speed: laden/unladen: 4.0/4.2km/h  |
| Service Weight               | (lb.) | 1584  |

AC Drive Motor  
1500 Watt



# EKKO

MATERIAL HANDLING EQUIPMENT

MOVING **AHEAD**

## WALKIE STRADDLE STACKER EB12E Series

- 2640-lbs. Capacity
- 119.4" to 138 in. Lift Height
- Narrow Aisles 7 ft.
- Adjustable Legs 45.7-59.1 in.
- Adjustable Forks 8.3-33.5 in.
- Batteries and Charger Included
- 3 Year Limited Warranty



## EB12E SERIES

Superior quality, maneuverable, compact, and durable for all your material handling applications. Ideal for small aisles and areas.

**WEIGHT CAPACITY:** 2640-3000 lbs. @ 24" load center

**LIFT HEIGHT:** 119.4" to 138" (9.95 ft. to 11.5 ft.)

**FORK LENGTH:** 45.3"

**ADJUSTABLE OUTRIGGERS:** 45.7" TO 59.1"

**ADJUSTABLE FORKS:** 8.3" TO 33.5"

**MAST HEIGHT:** 82" or 92"

**TURNING RADIUS:** 52.6"

**INTEGRAL BATTERY / CHARGER:** (2)12V 100AH, 24-volt deep cycle maintenance-free batteries with Internal direct connect 110A 110VAC plug-in automatic 24V/15A charger (both Included)

**SPEED TRAVEL:** 3.3 mph empty ; 3.0 mph loaded

**LIFTING SPEED:** 5.35 ips empty; 3.6 ips loaded

**LOWERING SPEED:** 3.85 ips empty; 4.4 ips loaded

**DRIVE WHEELS:** 9" x 3" polyurethane

**STABILITY:** 4" x 2" polyurethane

**LOAD WHEELS:** (2) 4" x 3" polyurethane per outrigger

**HYDRAULICS LIFTING MOTOR:** 24V 2200 Watt lifting motor with hardened chrome moly steel for durability.

**DRIVE MOTOR:** 24V 750Watt drive motor for efficiency and high torque.

**AC CONTROLLER:** 24V CURTIS Instrument provides performance through entire range of speed; Constant travel speed regardless of load; Battery discharge indicator combination gauge.

**BRAKES:** Electro-magnetic braking for secure stopping power; Electronic neutral braking for accurate control.

**OPERATOR CONTROLS:** Throttle, lifting, lowering, turtle mode and horn functions are located in the ergonomic handle; Offset steering handle to provide better visibility; Belly button reverse safety feature allows the unit to stop and reverse to avoid collision or injury.

**CHASSIS AND MAST:** Robotic Welding; Heavy duty steel chassis with I-beam mast for durability; Telescoping mast includes a protective steel guard.



# Walkie Straddle Stacker

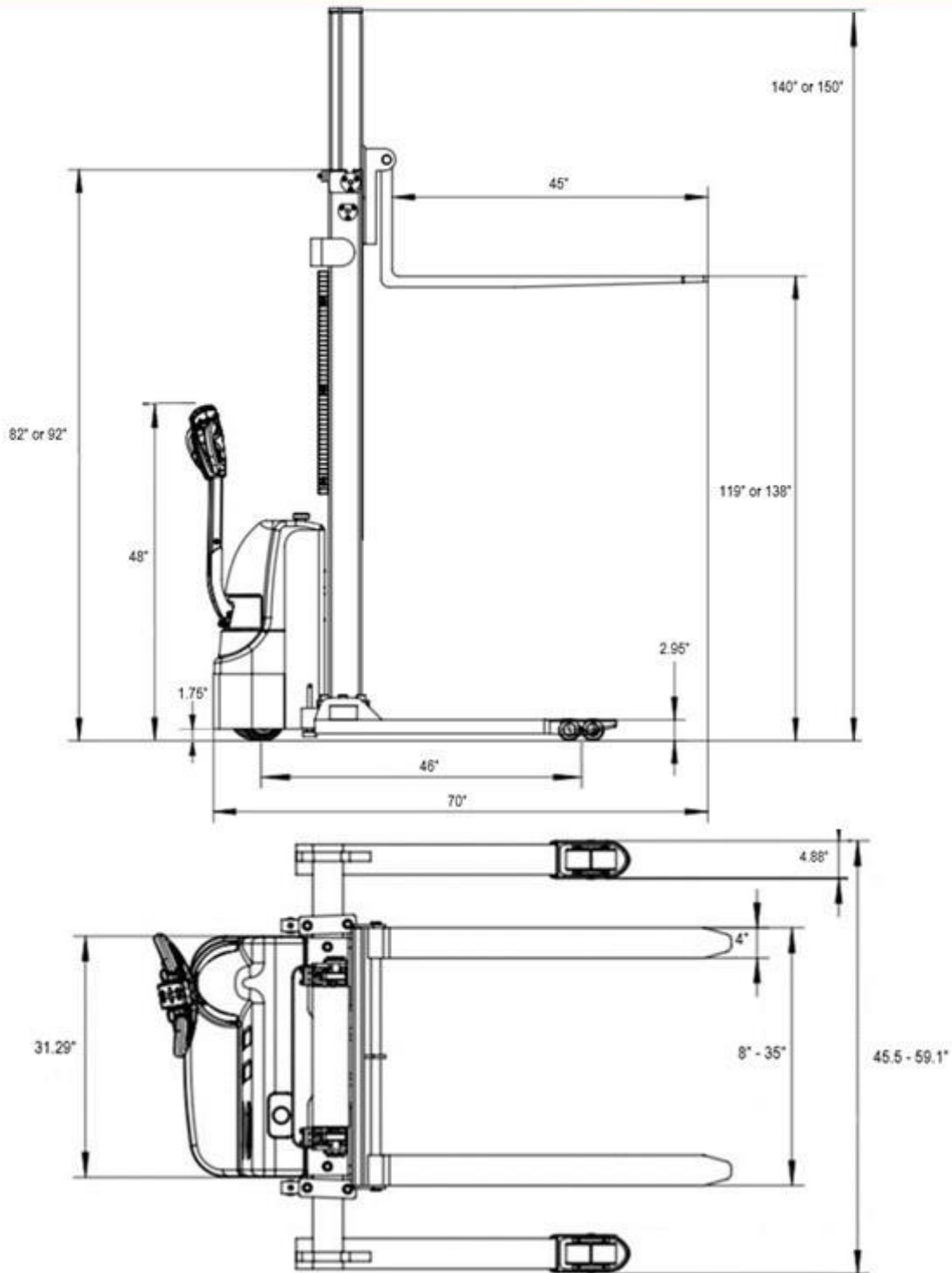

| MODEL #   | MAST | LIFT HEIGHT | SERVICE WEIGHT |
|-----------|------|-------------|----------------|
| EB12E     | 82"  | 119.4"      | 1420lbs        |
| EB12E-138 | 92"  | 138"        | 1450lbs        |

# EB12E-138 Full Powered Walkie Stacker

The EKKO EB12E-138 Electric Straddle Stacker is designed with the combination of the versatility of a forklift, reach truck and a walkie stacker. It is ideal for loading and unloading trucks, loading docks, stock rooms, manufacturing floors and warehousing.

Made from high quality steel and components with durable quality drives to withstand any terrain, usage, impact and directional changes for the use of any application with confidence and assurance.

- Load Capacity 2640 lb.
- Raised Height 138"
- Adjustable Forks 8.3-33.5"
- Adjustable Legs 45.7-59.1"
- Fork Length 45.3"
- Curtis Instrument Controller
- 24V Drive Motor
- 24V Lift Motor
- Battery 2\*12V/100Ah
- Polyurethane Wheels
- Ergonomic Handle and Controls
- Steel Construction
- Robotic Welding
- 3 Year Limited Warranty

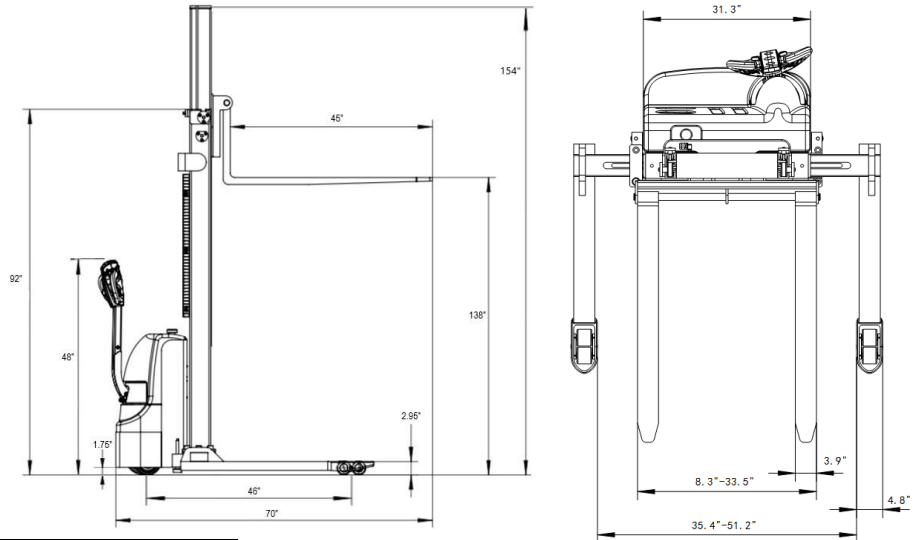

| Model                        |       | EB12E-138   |
|------------------------------|-------|---|
| Load capacity                | (lb.) | 2640  |
| The max. lifting height      | (in)  | 138"  |
| Load center distance         | (in)  | 24  |
| Fork length                  | (in)  | 45.3  |
| Single fork width            | (in)  | 4   |
| Overall fork width           | (in)  | 8.3-33.5  |
| Lowered fork height          | (in)  | 2.35  |
| Fixed leg length             | (in)  | 36.5  |
| Adjustable legs              | (in)  | 45.5-59.1   |
| Turning radius               | (in)  | 52.6  |
| Overall length               | (in)  | 70  |
| Max Overall width            | (in)  | 61  |
| Extended mast height         | (in)  | 154   |
| Lowered mast height          | (in)  | 92  |
| Battery voltage (dimensions) | (in)  | 2×12V/100AH (10/6.6/8.5)  |
| Internal Charger             | (V/A) | 24V/15A   |
| Lifting Motor                | (V/W) | 2.2kw. Lift speed, laden/unladen:92/136mm/s<br>Lowering speed, laden/unladen:112/98mm/s |
| Driving Motor                | (W)   | 0.75kw. Driving speed: laden/unladen:4.0/4.2km/h  |
| Service Weight               | (lb.) | 1450  |



# EKKO

MATERIAL HANDLING EQUIPMENT

MOVING **AHEAD**

## WALKIE STRADDLE STACKER EB12E Series

- 2640-lbs. Capacity
- 119.4" to 138 in. Lift Height
- Narrow Aisles 7 ft.
- Adjustable Legs 45.7-59.1 in.
- Adjustable Forks 8.3-33.5 in.
- Batteries and Charger Included
- 3 Year Limited Warranty



## EB12E SERIES

Superior quality, maneuverable, compact, and durable for all your material handling applications. Ideal for small aisles and areas.

**WEIGHT CAPACITY:** 2640-3000 lbs. @ 24" load center

**LIFT HEIGHT:** 119.4" to 138" (9.95 ft. to 11.5 ft.)

**FORK LENGTH:** 45.3"

**ADJUSTABLE OUTRIGGERS:** 45.7" TO 59.1"

**ADJUSTABLE FORKS:** 8.3" TO 33.5"

**MAST HEIGHT:** 82" or 92"

**TURNING RADIUS:** 52.6"

**INTEGRAL BATTERY / CHARGER:** (2)12V 100AH, 24-volt deep cycle maintenance-free batteries with Internal direct connect 110A 110VAC plug-in automatic 24V/15A charger (both Included)

**SPEED TRAVEL:** 3.3 mph empty ; 3.0 mph loaded

**LIFTING SPEED:** 5.35 ips empty; 3.6 ips loaded

**LOWERING SPEED:** 3.85 ips empty; 4.4 ips loaded

**DRIVE WHEELS:** 9" x 3" polyurethane

**STABILITY:** 4" x 2" polyurethane

**LOAD WHEELS:** (2) 4" x 3" polyurethane per outrigger

**HYDRAULICS LIFTING MOTOR:** 24V 2200 Watt lifting motor with hardened chrome moly steel for durability.

**DRIVE MOTOR:** 24V 750Watt drive motor for efficiency and high torque.

**AC CONTROLLER:** 24V CURTIS Instrument provides performance through entire range of speed; Constant travel speed regardless of load; Battery discharge indicator combination gauge.

**BRAKES:** Electro-magnetic braking for secure stopping power; Electronic neutral braking for accurate control.

**OPERATOR CONTROLS:** Throttle, lifting, lowering, turtle mode and horn functions are located in the ergonomic handle; Offset steering handle to provide better visibility; Belly button reverse safety feature allows the unit to stop and reverse to avoid collision or injury.

**CHASSIS AND MAST:** Robotic Welding; Heavy duty steel chassis with I-beam mast for durability; Telescoping mast includes a protective steel guard.



# Walkie Straddle Stacker

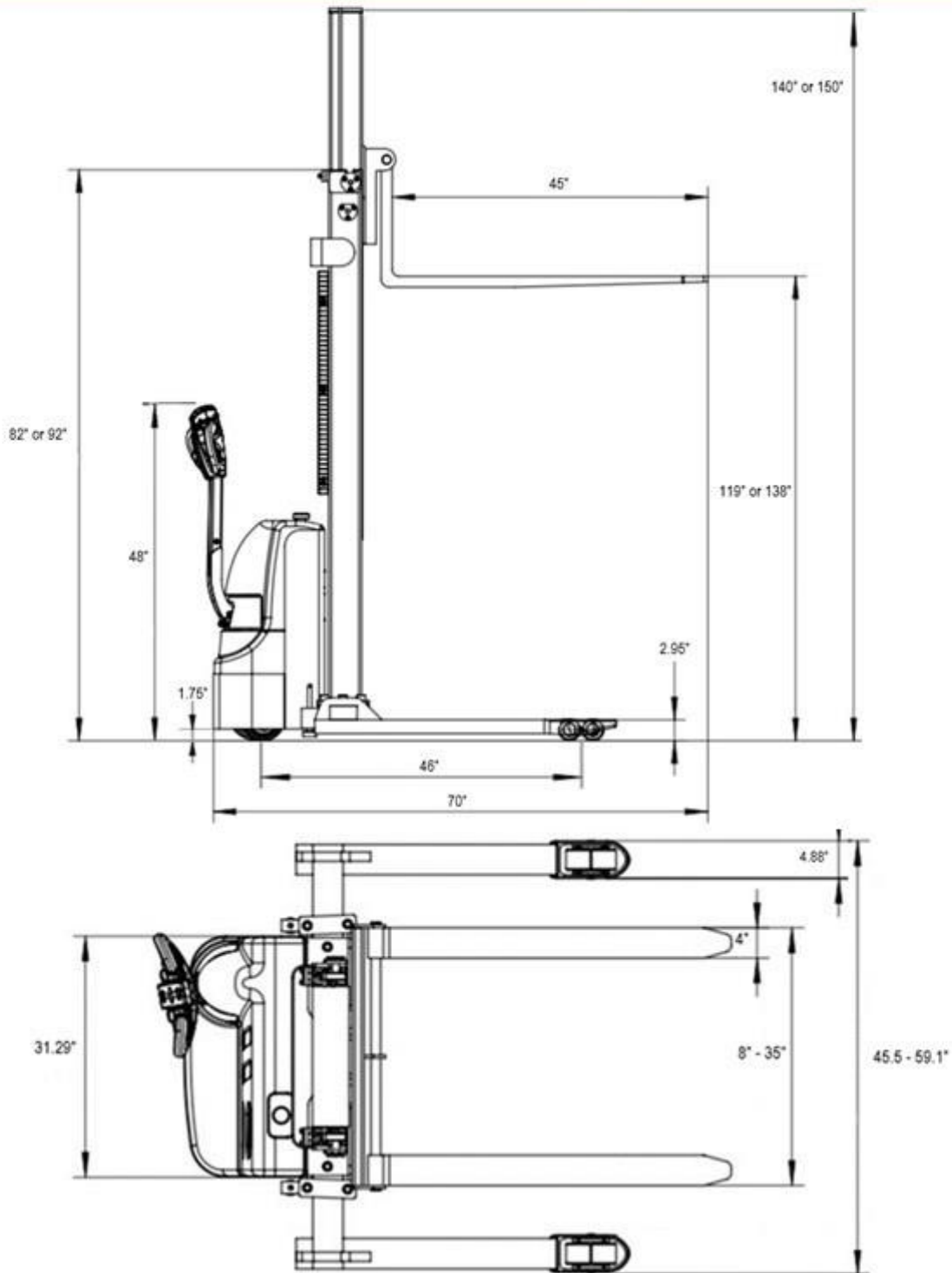

| MODEL #   | MAST | LIFT HEIGHT | SERVICE WEIGHT |
|-----------|------|-------------|----------------|
| EB12E     | 82"  | 119.4"      | 1420lbs        |
| EB12E-138 | 92"  | 138"        | 1450lbs        |