

# EB13E-138 Full Powered Walkie Stacker

The EKKO EB13E-138 Electric Straddle Stacker is designed with the combination of the versatility of a forklift, reach truck and a walkie stacker. It is ideal for loading and unloading trucks, loading docks, stock rooms, manufacturing floors and warehousing.

Made from high quality steel and components with durable quality drives to withstand any terrain, usage, impact and directional changes for the use of any application with confidence and assurance.

- Load Capacity 2800 lb
- Raised Height 138"
- Adjustable Forks 8.3-33.5"
- Adjustable Legs 45.7-59.1"
- Fork Length 45.3"
- Curtis Instrument Controller
- **24V Center Drive Motor**
- 24V Lift Motor
- Battery 2\*12V/100Ah
- Polyurethane Wheels
- Ergonomic Handle and Controls
- Steel Construction
- Robotic Welding
- 3 Year Limited Warranty

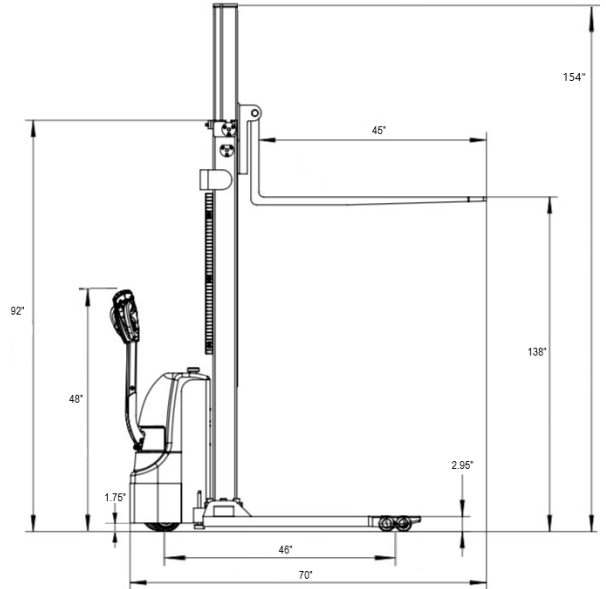

Model		EB13E-138
Load capacity	(lb)	2800
The max. lifting height	(in)	138"
Load center distance	(in)	24
Fork length	(in)	45.3
Single fork width	(in)	4
Overall fork width	(in)	8.3-33.5
Lowered fork height	(in)	2.35
Fixed leg length	(in)	36.5
Adjustable legs	(in)	45.5-59.1
Turning radius	(in)	52.6
Overall length	(in)	70
Max Overall width	(in)	61
Extended mast height	(in)	154
Lowered mast height	(in)	92
Battery voltage (dimensions)	(in)	2 × 12V/100AH (10/6.6/8.5)
Internal Charger	(V/A)	24V/15A
Lifting Motor	(V/W)	2000 Watt, Lift speed, laden/unladen:92/136mm/s Lowering speed, laden/unladen:112/98mm/s
Driving Motor	(W)	750 Watt, Driving speed: laden/unladen:4.0/4.2km/h
Service Weight	(lb)	1450

# EB13E Full Powered Walkie Stacker

The EKKO EB13E Electric Straddle Stacker is designed with the combination of the versatility of a forklift, reach truck and a walkie stacker. It is ideal for loading and unloading trucks, loading docks, stock rooms, manufacturing floors and warehousing.

Made from high quality steel and components with durable quality drives to withstand any terrain, usage, impact and directional changes for the use of any application with confidence and assurance.

- Load Capacity 2800 lb
- Raised Height 119"
- Adjustable Forks 8.3-33.5"
- Adjustable Legs 45.7-59.1"
- Fork Length 45.3"
- Curtis Instrument Controller
- **24V Center Drive Motor**
- 24V Lift Motor
- Battery 2\*12V/100Ah
- Polyurethane Wheels
- Ergonomic Handle and Controls
- Steel Construction
- Robotic Welding
- 3 Year Limited Warranty

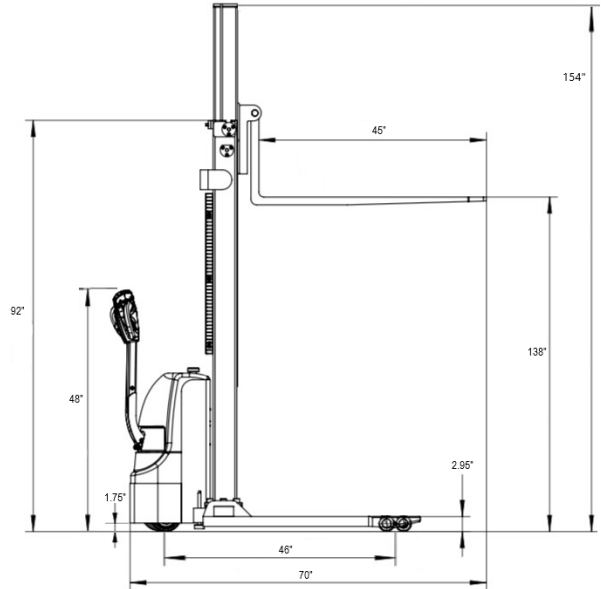

Model		EB13E
Load capacity	(lb)	2800
The max. lifting height	(in)	119"
Load center distance	(in)	24
Fork length	(in)	45.3
Single fork width	(in)	4
Overall fork width	(in)	8.3-33.5
Lowered fork height	(in)	2.35
Fixed leg length	(in)	36.5
Adjustable legs	(in)	45.5-59.1
Turning radius	(in)	52.6
Overall length	(in)	70
Max Overall width	(in)	61
Extended mast height	(in)	135
Lowered mast height	(in)	82
Battery voltage (dimensions)	(in)	2 × 12V/100AH (10/6.6/8.5)
Internal Charger	(V/A)	24V/15A
Lifting Motor	(V/W)	2000 Watt, Lift speed, laden/unladen:92/136mm/s Lowering speed, laden/unladen:112/98mm/s
Driving Motor	(W)	750 Watt, Driving speed: laden/unladen:4.0/4.2km/h
Service Weight	(lb)	1450

# EKKO<sup>®</sup>

MATERIAL HANDLING EQUIPMENT

**MOVING AHEAD**

# WALKIE STRADDLE STACKER EB13E-138

- 3000 lbs. Capacity
- 138 in. Lift Height
- Narrow Aisles 8 ft.
- Adjustable Legs 45.5-59.1 in.
- Adjustable Forks 8.3-33.5 in.
- 24V Center Drive Motor
- Curtis Instrument Controller
- Batteries and Charger Included
- 3 Year Limited Warranty



[www.ekkolifts.com](http://www.ekkolifts.com)

## EB13E-138 SERIES

**Superior quality, maneuverable, compact, and durable for all your material handling applications. Ideal for small aisles and areas.**

**WEIGHT CAPACITY:** 3000 lbs. @ 24" load center

**LIFT HEIGHT:** 138 (11.5 ft)

**FORK LENGTH:** 45.3"

**ADJUSTABLE OUTRIGGERS:** 45.7" - 59.1"

**ADJUSTABLE FORKS:** 8.3" - 33.5"

**MAST HEIGHT:** 92"

**TURNING RADIUS:** 52.6"

**BATTERY / CHARGER:** 24V/100Ah, 24-volt deep cycle maintenance-free batteries with internal direct connect 110A 110VAC plug-in automatic 24V/15A charger (both Included)

**SPEED TRAVEL:** 3.3 mph empty ; 3.0 mph loaded

**LIFTING SPEED:** 5.35 ips empty; 3.6 ips loaded

**LOWERING SPEED:** 3.85 ips empty; 4.4 ips loaded

**DRIVE WHEELS:** 9" x 3" polyurethane

**STABILITY:** 4" x 2" polyurethane

**LOAD WHEELS:** (2) 4" x 3" polyurethane per outrigger

**HYDRAULICS LIFTING MOTOR:** 24V 2200 Watt lifting motor with hardened chrome moly steel for durability.

**DRIVE MOTOR:** 24V 750Watt AC drive motor for efficiency and high torque.

**AC CONTROLLER:** 24V CURTIS Instrument provides performance through entire range of speed; Constant travel speed regardless of load; Battery discharge indicator combination gauge.

**BRAKES:** Electro-magnetic braking for secure stopping power; Electronic neutral braking for accurate control.

**OPERATOR CONTROLS:** Throttle, lifting, lowering, turtle mode and horn functions are located in the ergonomic handle; Offset steering handle to provide better visibility; Belly button reverse safety feature allows the unit to stop and reverse to avoid collision or injury.

**CHASSIS AND MAST:** Robotic Welding; Heavy duty steel chassis with I-beam mast for durability; Telescoping mast includes a protective steel guard.



# Walkie Straddle Stacker

# EKKO®

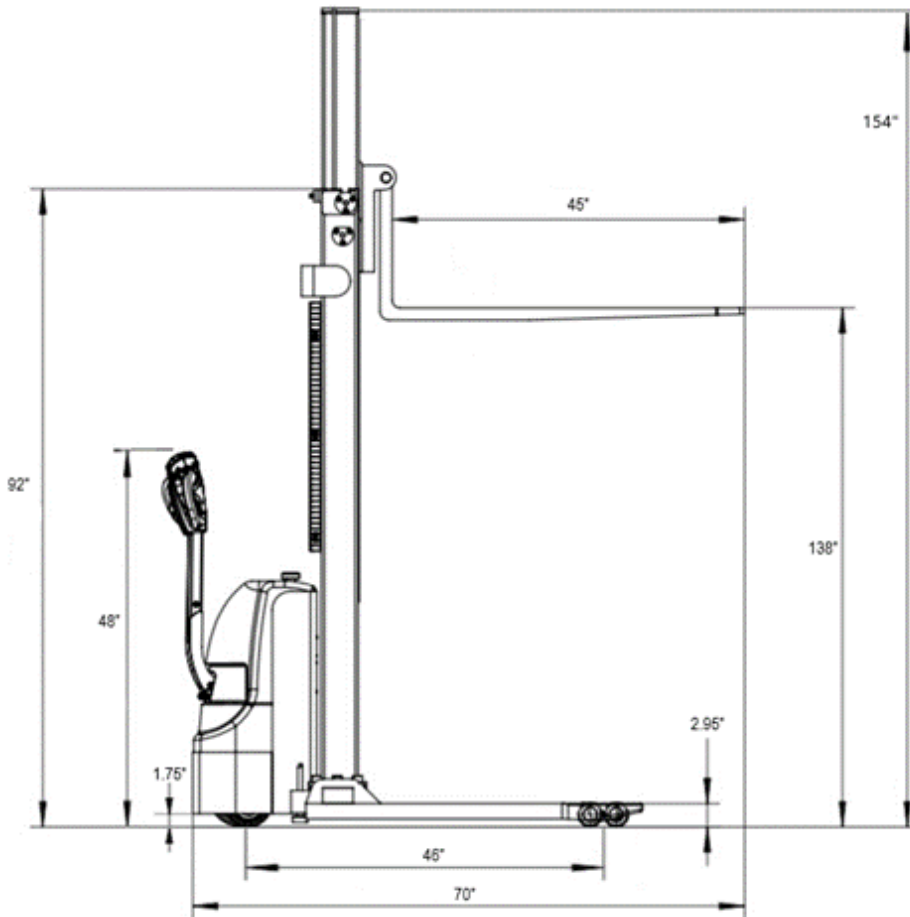

MODEL #	MAST	LIFT HEIGHT	MAX MAST HEIGHT	SERVICE WEIGHT
EB13E-138	92"	138"	154"	1450

**EKKO®**  
MATERIAL HANDLING EQUIPMENT  
**MOVING AHEAD**

1761 W. Holt Ave.  
Pomona, CA 91768 USA  
T: (877) 232-6517 F: (909) 222-6861

AUTHORIZED DEALERS ONLY  
[www.ekkolifts.com](http://www.ekkolifts.com)

# EKKO<sup>®</sup>

MATERIAL HANDLING EQUIPMENT

**MOVING AHEAD**

# WALKIE STRADDLE STACKER EB13E

- 2800 lbs. Capacity
- 119 in. Lift Height
- Narrow Aisles 8 ft.
- Adjustable Legs 45.5-59.1 in.
- Adjustable Forks 8.3-33.5 in.
- 24V Center Drive Motor
- Curtis Instrument Controller
- Batteries and Charger Included
- 3 Year Limited Warranty



[www.ekkolifts.com](http://www.ekkolifts.com)

## EB13E

**Superior quality, maneuverable, compact, and durable for all your material handling applications. Ideal for small aisles and areas.**

**WEIGHT CAPACITY:** 2800 lbs. @ 24" load center

**LIFT HEIGHT:** 119 (9.95 ft)

**FORK LENGTH:** 45.3"

**ADJUSTABLE OUTRIGGERS:** 45.7" - 59.1"

**ADJUSTABLE FORKS:** 8.3" - 33.5"

**MAST HEIGHT:** 82"

**TURNING RADIUS:** 52.6"

**BATTERY / CHARGER:** 24V/100Ah, 24-volt deep cycle maintenance-free batteries with internal direct connect 110A 110VAC plug-in automatic 24V/15A charger (both Included)

**SPEED TRAVEL:** 3.3 mph empty ; 3.0 mph loaded

**LIFTING SPEED:** 5.35 ips empty; 3.6 ips loaded

**LOWERING SPEED:** 3.85 ips empty; 4.4 ips loaded

**DRIVE WHEELS:** 9" x 3" polyurethane

**STABILITY:** 4" x 2" polyurethane

**LOAD WHEELS:** (2) 4" x 3" polyurethane per outrigger

**HYDRAULICS LIFTING MOTOR:** 24V 2200 Watt lifting motor with hardened chrome moly steel for durability.

**DRIVE MOTOR:** 24V 750Watt drive motor for efficiency and high torque.

**AC CONTROLLER:** 24V CURTIS Instrument provides performance through entire range of speed; Constant travel speed regardless of load; Battery discharge indicator combination gauge.

**BRAKES:** Electro-magnetic braking for secure stopping power; Electronic neutral braking for accurate control.

**OPERATOR CONTROLS:** Throttle, lifting, lowering, turtle mode and horn functions are located in the ergonomic handle; Offset steering handle to provide better visibility; Belly button reverse safety feature allows the unit to stop and reverse to avoid collision or injury.

**CHASSIS AND MAST:** Robotic Welding; Heavy duty steel chassis with I-beam mast for durability; Telescoping mast includes a protective steel guard.



# Walkie Straddle Stacker

# EKKO®

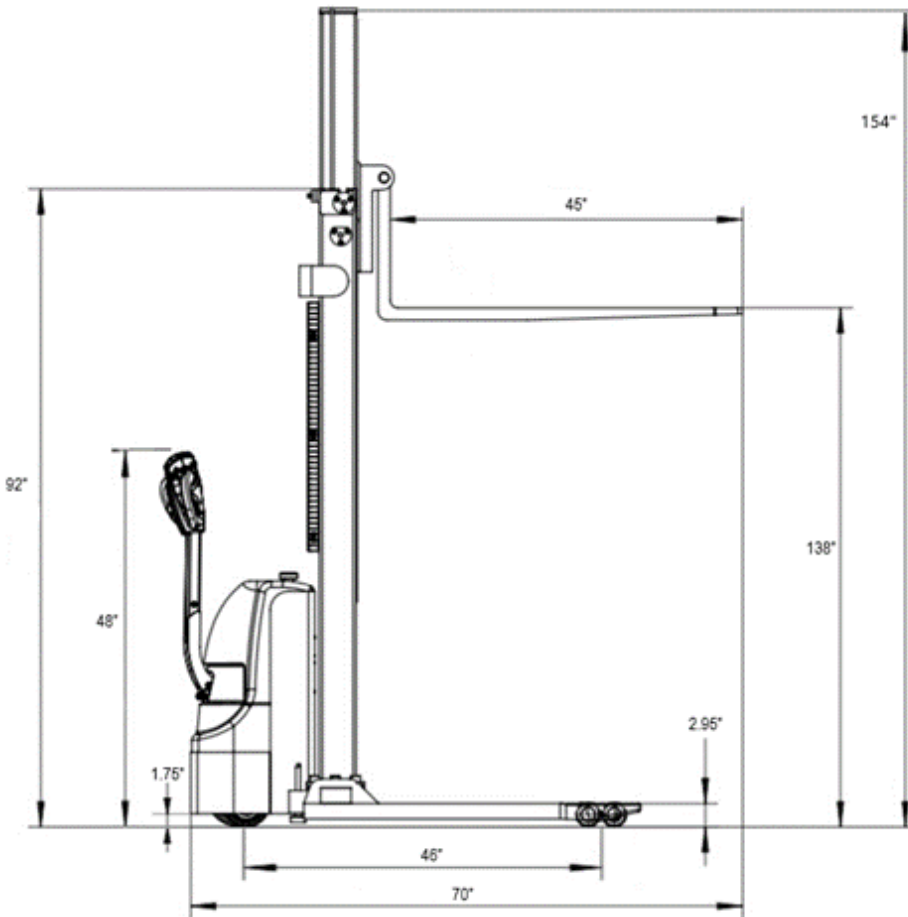

MODEL #	MAST	LIFT HEIGHT	MAX MAST HEIGHT	SERVICE WEIGHT
EB13E-138	92"	138"	154"	1450
EB13E	82"	119"	143"	1420

**EKKO®**  
MATERIAL HANDLING EQUIPMENT  
**MOVING AHEAD**

1761 W. Holt Ave.  
Pomona, CA 91768 USA  
T: (877) 232-6517 F: (909) 222-6861

AUTHORIZED DEALERS ONLY  
[www.ekkolifts.com](http://www.ekkolifts.com)