

## EB16EA Full Powered Walkie Stacker

The EKKO EB16EA Electric Straddle Stacker is designed with the combination of the versatility of a forklift, walkie stacker. It is ideal for loading and unloading trucks, loading docks, stock rooms, manufacturing floors and warehousing.

Made from high quality steel and components with durable quality drives to withstand any terrain, usage, impact and directional changes for the use of any application with confidence and assurance.

- Load Capacity 4400 lb.
- Raised Height 216"
- Adjustable Forks 9.8-31.5"
- Adjustable Legs 38.06-51.8"
- Fork Length 45.28"
- Free Lift 76.25"
- EPS (Electric Power Steering)
- Curtis Instrument Controller
- 24V Center AC Drive Motor
- 24V Lift Motor
- Triple Mast
- Battery 24V/210Ah
- Polyurethane Wheels
- Ergonomic Handle and Controls
- Steel Construction
- Robotic Welding
- 3 Year Limited Warranty



Model		EB16EA
Load capacity	(lb.)	4400
The max. lifting height	(in)	216
Load center distance	(in)	24
Free Lift	(in)	76.25
EPS (Elec. Power Steer)		Yes
Fork length	(in)	45.28
Single fork width	(in)	4.7
Overall fork width	(in)	9.8-31.5
Lowered fork height	(in)	1.58
Fixed leg length	(in)	42
Adjustable legs	(in)	38.06-51.81
Turning radius	(in)	69.09
Overall length	(in)	81.69
Max width	(in)	46.93-60.71
Extended mast height	(in)	253.15
Lowered mast height	(in)	98.03
Battery voltage	(V/Ah)	24/210Ah
Charger	(V/A)	24V/30A
Lifting Motor	(W)	3000-Watt, Lift speed, laden/unladen:95/160m/s Lowering speed, laden/unladen:130/110mm/s
AC Driving Motor	(W)	3000 Watt, Driving speed: laden/unladen: 5.2/5.5km/h
Service Weight	(lb.)	3542

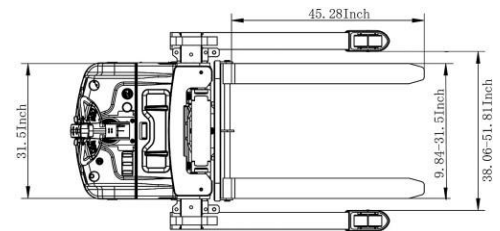
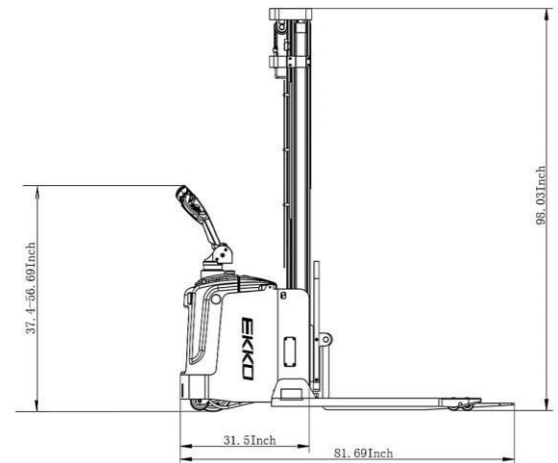

# EKKO®

MATERIAL HANDLING EQUIPMENT

**MOVING AHEAD**

# WALKIE STRADDLE STACKER EB16EA

- 4400 lbs. Capacity
- 216 in. Lift Height
- Free Lift 76.25 In.
- EPS (Electric Power Steering)
- AC ZF Center Drive Motor
- Narrow Aisles 8 ft.
- Adjustable Legs 38.06-51.81 in.
- Adjustable Forks 9.8-31.5 in.
- Curtis Instrument Controller
- Batteries and Charger Included
- 3 Year Limited Warranty



[www.ekkolifts.com](http://www.ekkolifts.com)

## EB16EA

**Superior quality, maneuverable, compact, and durable for all your material handling applications. Ideal for small aisles and areas.**

**WEIGHT CAPACITY:** 4400 lbs. @ 24" load center

**LIFT HEIGHT:** 216" (18 ft.)

**FORK LENGTH:** 45.28"

**ADJUSTABLE OUTRIGGERS:** 38.06-51.81"

**ADJUSTABLE FORKS:** 9.8-31.5"

**MAST HEIGHT:** 98.03"

**TURNING RADIUS:** 69.09"

**BATTERY / CHARGER:** 24V/210Ah, 24-volt deep cycle maintenance-free batteries with external direct connect 110A 110VAC plug-in automatic 24V/30A charger (both Included)

**SPEED TRAVEL:** 3.3 mph empty ; 3.0 mph loaded

**LIFTING SPEED:** 5.35 ips empty; 3.6 ips loaded

**LOWERING SPEED:** 3.85 ips empty; 4.4 ips loaded

**DRIVE WHEELS:** 9" x 3" polyurethane

**STABILITY:** 4" x 2" polyurethane

**LOAD WHEELS:** (2) 4" x 3" polyurethane per outrigger

**HYDRAULICS LIFTING MOTOR:** 24V 3000-Watt lifting motor with hardened chrome moly steel for durability.

**DRIVE MOTOR:** 24V AC ZF 3000Watt drive motor for efficiency and high torque. **EPS (Electric Power Steering)**

**AC CONTROLLER:** 24V CURTIS Instrument provides performance through entire range of speed; Constant travel speed regardless of load; Battery discharge indicator combination gauge.

**BRAKES:** Electro-magnetic braking for secure stopping power; Electronic neutral braking for accurate control.

**OPERATOR CONTROLS:** Throttle, lifting, lowering, turtle mode and horn functions are in the ergonomic handle; Offset steering handle to provide better visibility; Belly button reverse safety feature allows the unit to stop and reverse to avoid collision or injury.

**CHASSIS AND MAST:** Robotic Welding; Heavy duty steel chassis with I-beam mast for durability; Telescoping mast includes a protective steel guard.



# Walkie Straddle Stacker

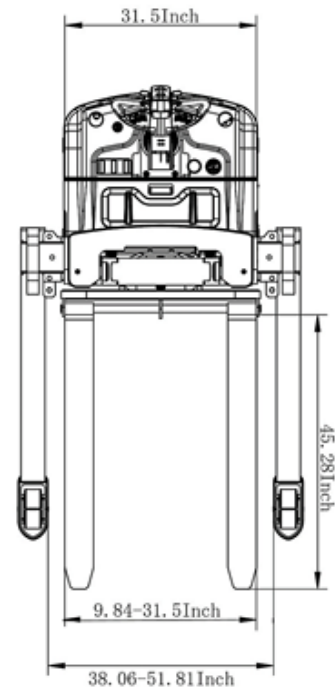
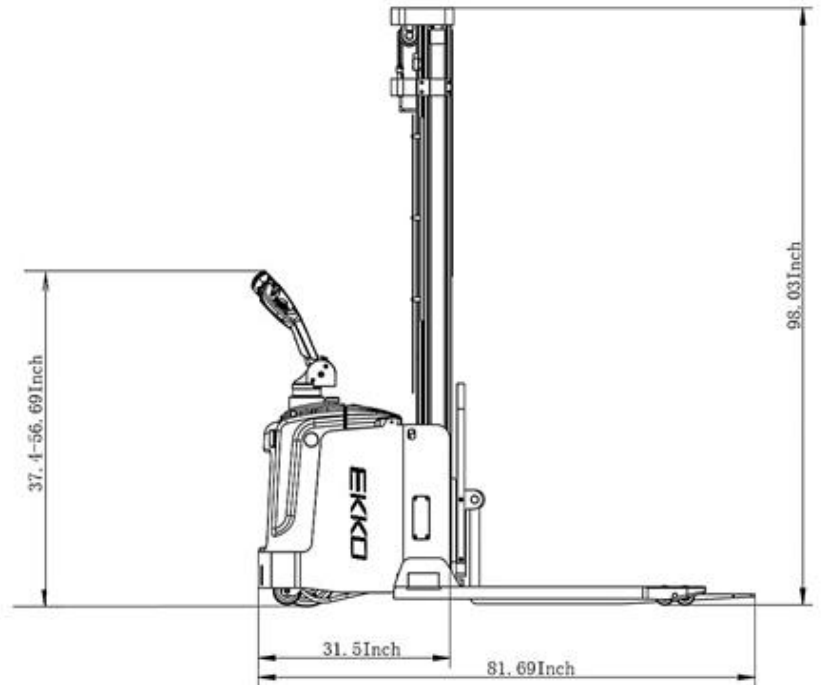

MODEL #	MAST	LIFT HEIGHT	MAX MAST HEIGHT	SERVICE WEIGHT
EB16EA	98.03"	216"	253.15"	3542