

# EH15TH Moving Mast Walkie Reach Truck



Model		EH15TH
Lift		Electric
Drive		Electric
Load capacity	(lb.)	3300
Load center distance	(in)	24
Lifting height	(in)	216
Free Lift	(in)	68"
Lowered mast height	(in)	97.3
Overall length	(in)	111.6
Overall width	(in)	41
Fork size, Thick/Width/Length	(in)	1.4/4/45.2
Fork adjust width	(in)	8.7-28
Reach Distance	(in)	19.7
Turning radius	(in)	67
Charger	(V/A)	24V/50A
Driving Motor	(V/W)	AC 24V/2.5kw
EPS Steering Motor	(V/W)	24/200W
Lifting Motor	(V/W)	24V/3000W
Battery voltage	(V/Ah)	24V/400Ah
Service Weight	(lb.)	4915

The EKKO EH15TH Moving Mast Walkie Reach Truck is designed with the combination of the versatility of a forklift, reach truck and a walkie stacker. It is ideal for loading and unloading trucks, loading docks, stock rooms, manufacturing floors and warehousing.

Made from high quality steel and components with durable quality drives to withstand any terrain, usage, impact and directional changes for the use of any application with confidence and assurance.

- Load Capacity 3300 lb.
- Raised Height 216" (18ft)
- Reach Distance of 19.7"
- Free Lift 68"
- Adjustable Forks 8.7-29.7
- Fork Length 45.2"
- Curtis Instrument Control
- EPS (Electronic Power Steer)
- 24V AC Drive Motor
- 24V Lift Motor
- Battery 24V/400Ah
- Polyurethane Wheels
- Ergonomic Handle and Control
- Steel Construction
- Robotic Welding
- Charger
- 3 Year Limited Warranty

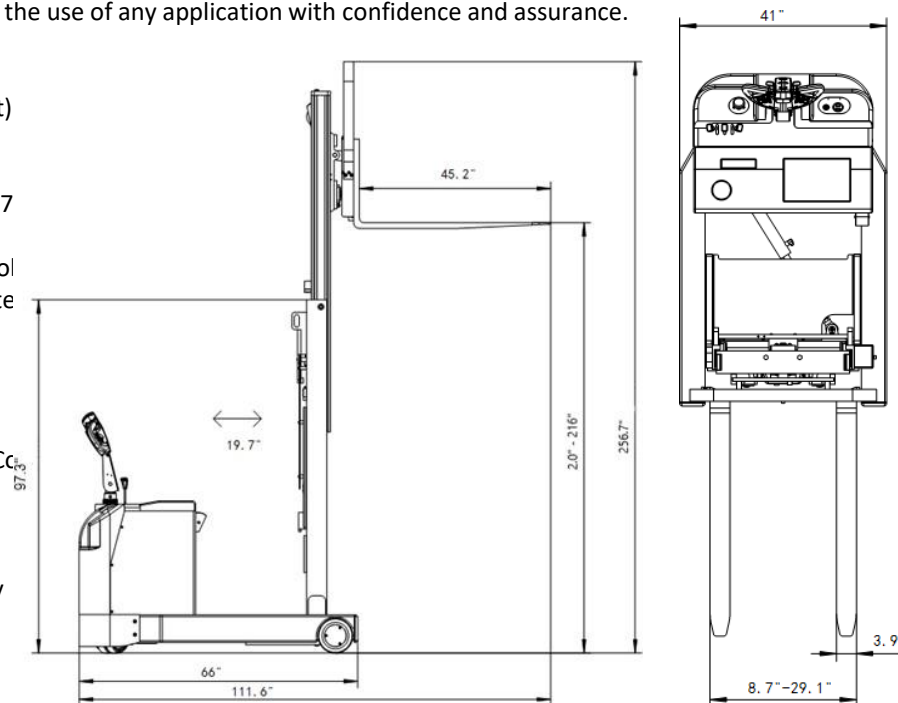

# EKKO<sup>®</sup>

MATERIAL HANDLING EQUIPMENT

**MOVING AHEAD**

## **WALKIE REACH TRUCK EH15T SERIES**



- Load Capacity 3300 lbs.
- Lift Height 138 - 216 in.
- EPS (Elec. Power Steer)
- Extended Reach 19.7 in.
- Extended Length 111.6 in.
- Curtis Instrument Controller
- Tilt 2/5 degree
- Mast Height 82 – 93.3 in.
- Batteries & Charger Included
- 3 Year Limited Warranty

## EH15T SERIES

**Superior quality, maneuverable, compact, and durable for all your material handling applications. Ideal for small aisles and areas.**

**WEIGHT CAPACITY:** 3300 lbs. @ 24" load center

**LIFT HEIGHT:** 138" or 216" (11.5 ft. or 18 ft)

**FORK LENGTH:** 45.2"

**MAST HEIGHT:** 82" or 93.3"

**TURNING RADIUS:** 67"

**TILT:** 2/5 degree

**EXTENDED REACH:** 19.7"

**INTEGRAL BATTERY / CHARGER:** 24V 270-400AH, 24-volt Industrial batteries with external direct connect 110A 110VAC plug-in automatic 24V/30A charger (both Included)

**BRAKING:** Electromagnetic Brakes

**SPEED TRAVEL:** 3.7 mph empty; 3.5 mph loaded

**LIFTING SPEED:** 5.1 ips empty; 4 ips loaded

**LOWERING SPEED:** 4.7 ips empty; 5.3 ips loaded

**DRIVE WHEELS:** 8.25" x 2.5" cushion

**LOAD WHEELS:** (2) 8.25" x 2.5" cushion

**HYDRAULICS LIFTING MOTOR:** 24V 3000 Watt lifting motor with hardened chrome moly steel for durability.

**DRIVE MOTOR:** 24V 1500 Watt AC drive motor for efficiency and high torque.

**STEERING MOTOR:** EPS (Electronic Power Steering) 24V 200 Watt

**AC CONTROLLER:** 24V CURTIS Instrument provides performance through entire range of speed; Constant travel speed regardless of load; Battery discharge indicator combination gauge.

**BRAKES:** Electro-magnetic braking for secure stopping power; Electronic neutral braking for accurate control.

**OPERATOR CONTROLS:** EPS (Electric Power Steering), tilt lifting, lowering, horn functions are located in the ergonomic handle; Belly button reverse safety feature allows the unit to stop and reverse to avoid collision or injury.

**CHASSIS AND MAST:** Robotic Welding; Heavy duty steel chassis with I-beam mast for durability; Telescoping mast.



# Walkie Reach Truck

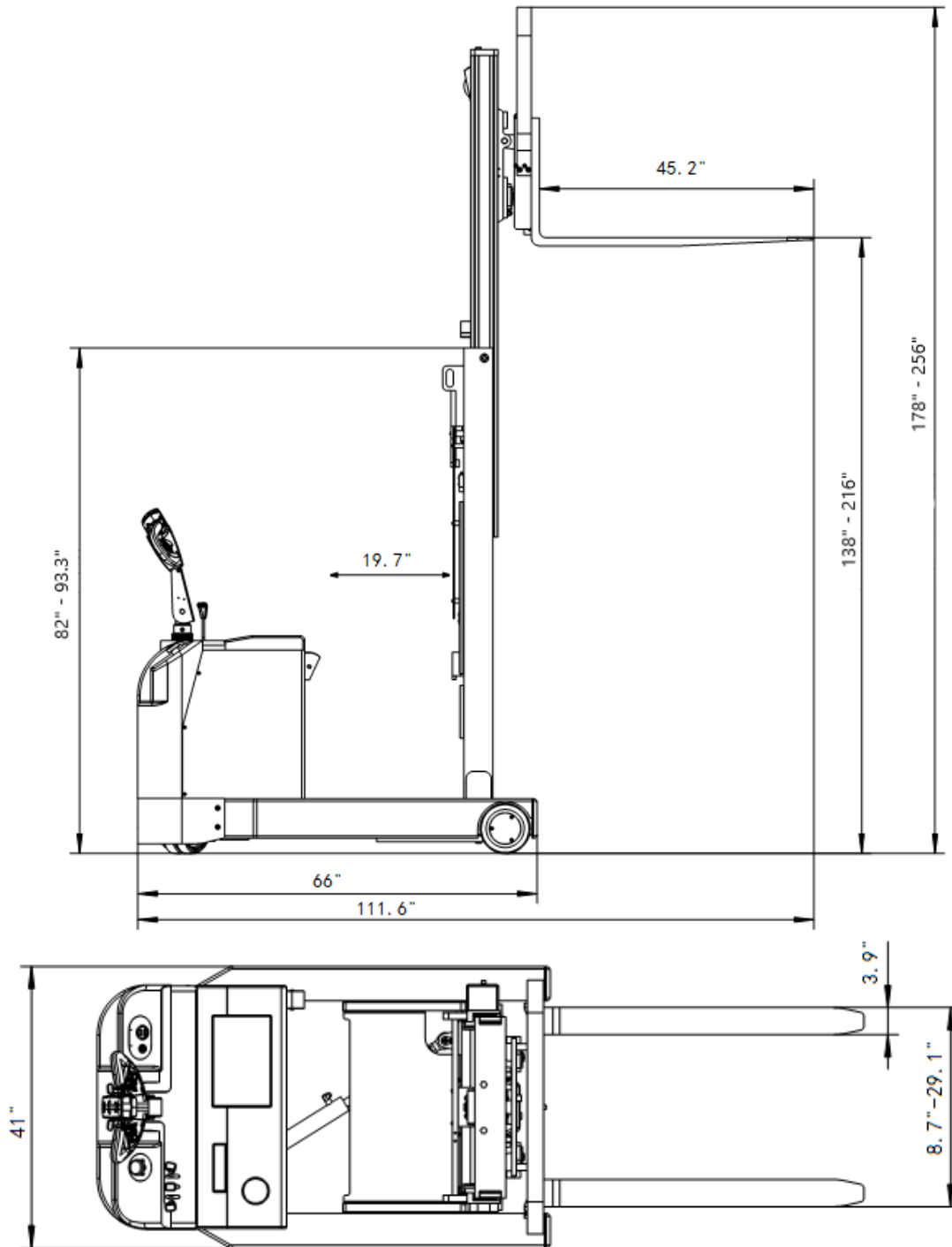

MODEL #	MAST	LIFT HEIGHT	MAX MAST HEIGHT	TOTAL LENGTH	SERVICE WEIGHT
EH15T	82"	138"	178"	111.6"	4200
EH15TH	93.3	216"	256"	111.6"	4915



1761 W. Holt Ave.  
 Pomona, CA 91768 USA  
 T: (877) 232-6517 F: (909) 222-6861

AUTHORIZED DEALERS ONLY  
[www.ekkolifts.com](http://www.ekkolifts.com)