

## EK15A 3 Wheel Electric Forklift

Model		EK15A
Lift		Electric
Drive		Electric
Load capacity	(lb.)	3300
Load center distance	(in)	24
Wheel base	(in)	43
Lifting height	(in)	177
Free lifting height	(in)	59
Lowered mast height	(in)	79.6
Mast/Fork carriage tilt forward/backward	( ° )	2/5
Side Shifting Forks		3-way valve
Overall length	(in)	106.6
Overall width	(in)	36
Fork size, Thick/Width/Length	(in)	1.4/4/45.3
Fork adjust width	(in)	8.7-29
Turning radius	(in)	53
Max gradient performance, laden/unladen	(%)	6/8
Lift speed, laden/unladen	(in/s)	4/5.5
Lowering speed, laden/unladen	(in/s)	5.3/4.7
Charger	(V/A)	24V/50A
Driving Motor	(V/W)	AC 24V/2000W
Lifting Motor	(V/W)	24V/2500W
Battery voltage	(V/Ah)	24V/400Ah (Side)
Service Weight	(lb.)	5665

The EKKO EK15A 3 Wheel Electric Forklift is designed for use for small aisles, limited spaces and budget. It is ideal for loading and unloading trucks, loading docks, stock rooms, manufacturing floors and warehousing.

Made from high quality steel and components with durable quality drives to withstand any terrain, usage, impact and directional changes for the use of any application with confidence and assurance.

- Load Capacity 3300 lb.
- Raised Height 177" (14.75ft)
- Side Shifting
- Free Lift 59"
- Adjustable Forks 8.7-29"
- Fork Length 45.3"
- Overhead Guard 77"
- EPS (Electric Power Steering)
- Curtis Instrument Controller
- 24V AC Drive Motor
- 24V Lift Motor
- Battery 24V/400Ah
- Solid Wheels
- Ergonomic Handle and Controls
- Steel Construction
- Robotic Welding
- Charger 24V/50Ah
- 3 Year Limited Warranty

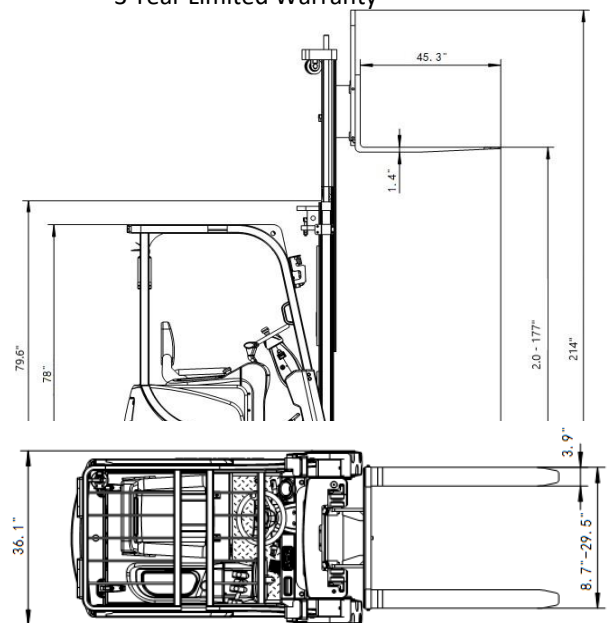

# EKKO<sup>®</sup>

MATERIAL HANDLING EQUIPMENT

**MOVING AHEAD**

## 3-WHEEL ELECTRIC FORKLIFT EK15A SERIES

- Load Capacity 3300 lbs.
- Lift Height 177 in. 3 Stage
- Side Shifting Forks
- Free Lift 59"
- EPS (Elec. Power Steer)
- Length 106.6 in.
- Curtis Controller
- Tilt 2/5 degree
- Mast Height 79.6 in.
- Overhead Guard 77 in.
- Batteries & Charger
- 3 Year Limited Warranty



## EK15A

**Superior quality, maneuverable, compact, and durable for all your material handling applications. Ideal for small aisles and areas.**

**WEIGHT CAPACITY:** 3300 lbs. @ 24" load center

**LIFT HEIGHT:** 177" (14.75 ft) 3 Stage

**SIDE SHIFTING FORKS:** 45.3"

**MAST HEIGHT:** 79.6"

**TURNING RADIUS:** 53

**FREE LIFT:** 59"

**TILT:** 2/5 degree

**INTEGRAL BATTERY / CHARGER:** 24V 400AH, 24-volt Industrial batteries with external direct connect 110A 110VAC plug-in automatic 24V/50A charger (both Included)

**BRAKING:** Drum brakes

**SPEED TRAVEL:** 6.21 mph empty ; 5 mph loaded

**LIFTING SPEED:** 5.5 ips empty; 4 ips loaded

**LOWERING SPEED:** 4.7 ips empty; 5.3 ips loaded

**DRIVE WHEELS:** 9.8" x 5" cushion

**LOAD WHEELS:** (2) 12" x 5" cushion

**HYDRAULICS LIFTING MOTOR:** 24V 2500 Watt lifting motor with hardened chrome moly steel for durability.

**DRIVE MOTOR:** 24V 2000 Watt AC drive motor for efficiency and high torque.

**AC CONTROLLER:** 24V Curtis provides performance through entire range of speed; Constant travel speed regardless of load; Battery discharge indicator combination gauge.

**BRAKES:** Drum Brakes with Electro-magnetic braking for secure stopping power; Electronic neutral braking for accurate control.

**LIGHTING:** LED Head lights and Brake lights.

**OPERATOR CONTROLS:** EPS (Electric Power Steering), tilt lifting, lowering, side shifting forks, horn functions are located in the ergonomic sit down; Led lighting.

**CHASSIS AND MAST:** Robotic Welding; Heavy duty steel chassis with I-beam mast for durability; Telescoping mast.



# 3-Wheel Electric Forklift

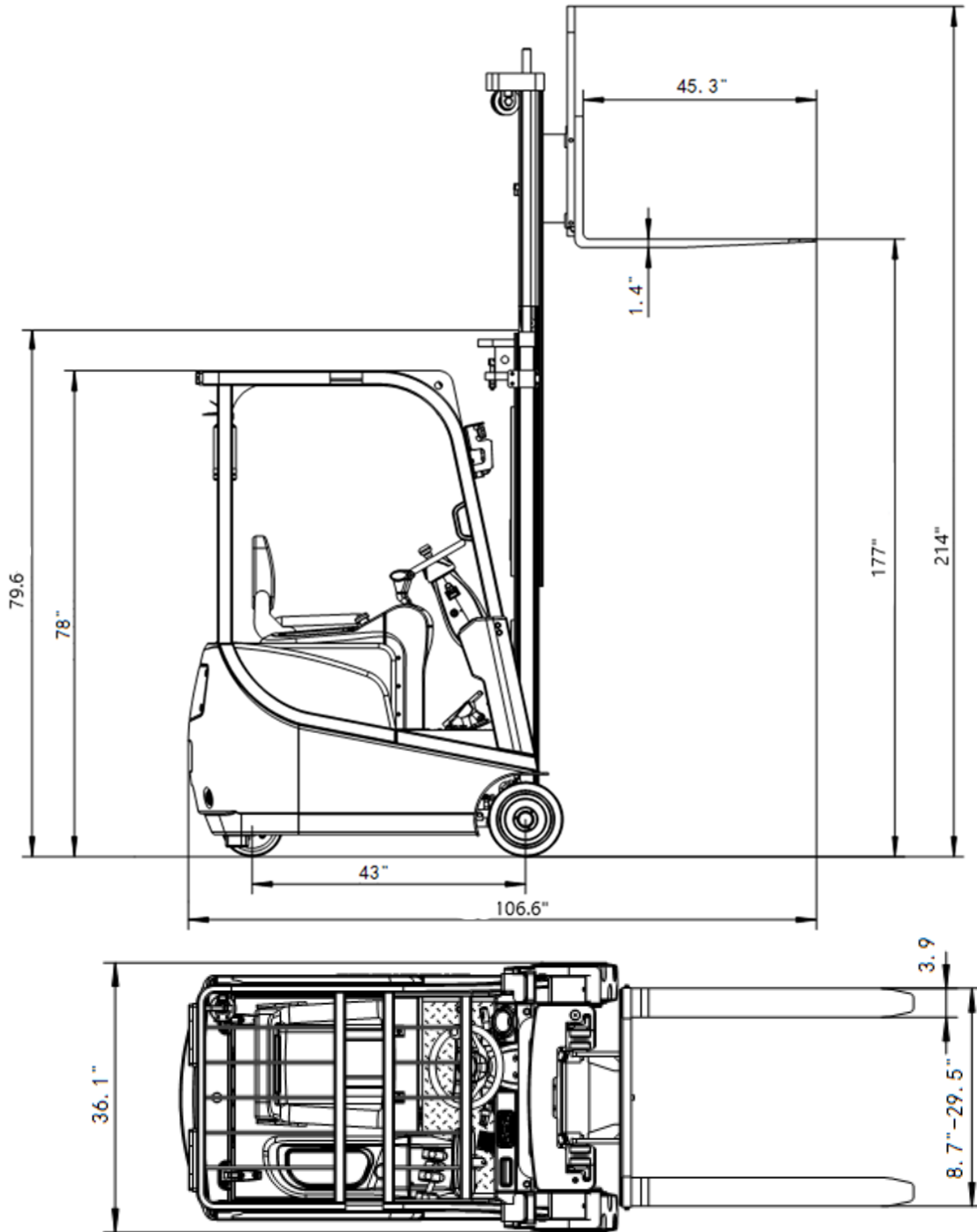

MODEL #	MAST	LIFT HEIGHT	MAX MAST HEIGHT	TOTAL LENGTH	SERVICE WEIGHT
EK15A	79.6"	177"	214"	106.6	5665