

EK18A-189LI 3 Wheel Electric Forklift

Model		EK18A-189Li
Lift		Electric
Drive		Electric
Load capacity	(lb.)	4,000
Load center distance	(in)	24
Wheel base	(in)	55.1
Lifting height	(in)	189
Free lifting height	(in)	46.5
Lowered mast height	(in)	86.2
Mast/Fork carriage tilt forward/backward	(°)	3/5
Side Shifting Forks		3-way valve
Overall length	(in)	116.9
Overall width	(in)	44.1
Fork size	(in)	42
Fork adjust width	(in)	8.7-29
Turning radius	(in)	65.9
Max gradient performance, laden/unladen	(%)	22/30
Lift speed, laden/unladen	(fpm)	78.7/118.1
Lowering speed, laden/unladen	(fpm)	114.2/98.4
Charger		Included
Driving Motor		AMOSFET
Lifting Motor	(HP)	18.8
Battery voltage	(V/Ah)	80V/202Ah Li
Service Weight	(lb.)	7,341

The EKKO E18A-189LI 3 Wheel Lithium Forklift is designed for use for all your material handling demands. It is ideal for loading and unloading trucks, loading docks, stock rooms, manufacturing floors and warehousing.

Made from high quality steel and components with durable quality drives to withstand any terrain, usage, impact and directional changes for the use of any application with confidence and assurance.

- Load Capacity 4000 lb.
- Raised Height 189" (15.75ft)
- Side Shifting Forks
- Free Lift 46.5"
- Adjustable Forks
- Hydraulic Steering
- ZAPI controller
- Battery 80V/202Ah Lithium (included)
- Solid Pneumatic Tires
- Ergonomic Handle and Controls
- Steel Construction
- Robotic Welding
- Charger Included
- 3 Year Limited Warranty

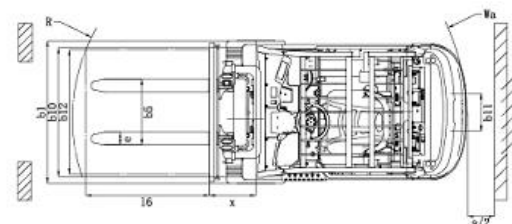
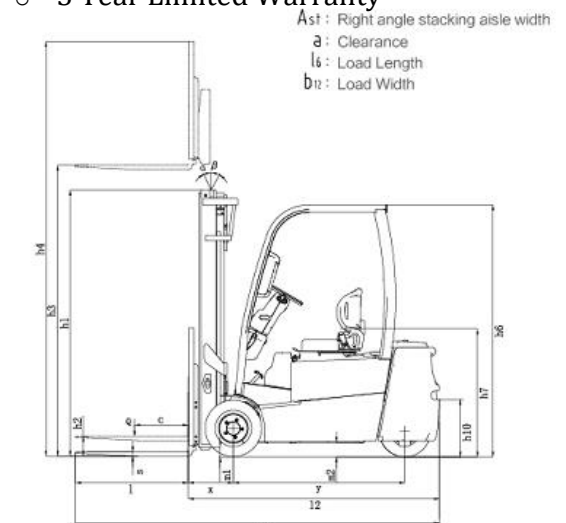

EKKO

MATERIAL HANDLING EQUIPMENT.

MOVING AHEAD

3-WHEEL ELECTRIC FORKLIFT EK15A-189Li SERIES

- Load Capacity 3300 lbs.
- Lift Height 189"
- **Side-Shift**
- Free Lift 62.56"
- EPS (Elec. Power Steer)
- Overall Width 36.1" 106.6" Length
- Curtis Controller
- Tilt 2/5 degree
- Mast Height 83.54 in.
- Overhead Guard 77.95 in.
- Batteries & Charger
- Lithium-Ion Battery
- 3 Year Limited Warranty



EK15A-189Li

Superior quality, maneuverable, compact, and durable for all your material handling applications. Ideal for small aisles and areas.

WEIGHT CAPACITY: 3300 lbs. @ 23.6" load center

LIFT HEIGHT: 189" (15.75 ft) 3 Stage

SIDE-SHIFT

Forks: 1.4" X 4" X 45"

MAST LOWERED HEIGHT: 83.54"

"Works in a 9.5 ft aisle with standard pallets"

TURNING RADIUS: 53.07

FREE LIFT: 62.56"

TILT: 2 degrees back/5 degrees forward

LITHIUM BATTERY / CHARGER: 24 Volt with 110 plug in

SPEED TRAVEL: 4.47 mph empty; 3.85 mph loaded

LIFTING SPEED: 215 mm/s empty; 135 mm/s loaded

LOWERING SPEED: 225 mm/s empty; 238 mm/s loaded

DRIVE WHEELS: Cushion Traction 9.8" X 5"

Rear Wheel: Cushion Traction 9.8" X 5"

REAR SINGLE DRIVE MOTOR: 1.7kw

AC CURTIS CONTROLLER: With "Safety Diagnostic Self Check" on electrical system before operating unit.

LIGHTING: LED Head lights, Brake lights, Strobe light and Pedestrian blue light.

OPERATOR CONTROLS: EPS (Electric Power Steering), tilt lifting, lowering, side shifting forks, horn functions are in the ergonomic operator compartment; Led lighting. Complete digital display, with digital battery discharge indicator. rear mirror, and fire extinguisher

CHASSIS AND MAST: Robotic Welding; Heavy duty steel chassis with I-beam mast for durability; Telescoping mast.



3-Wheel Electric Forklift

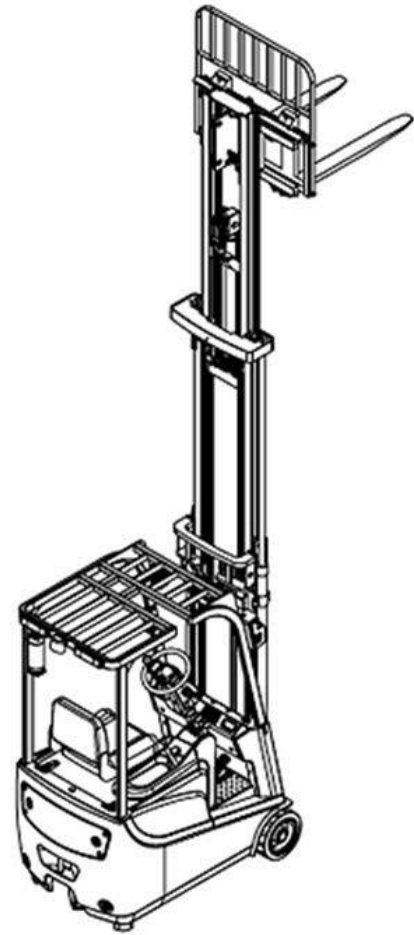
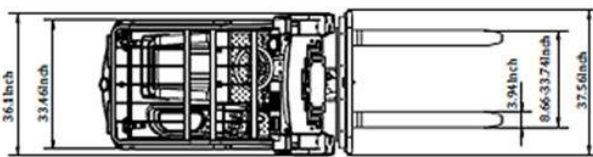
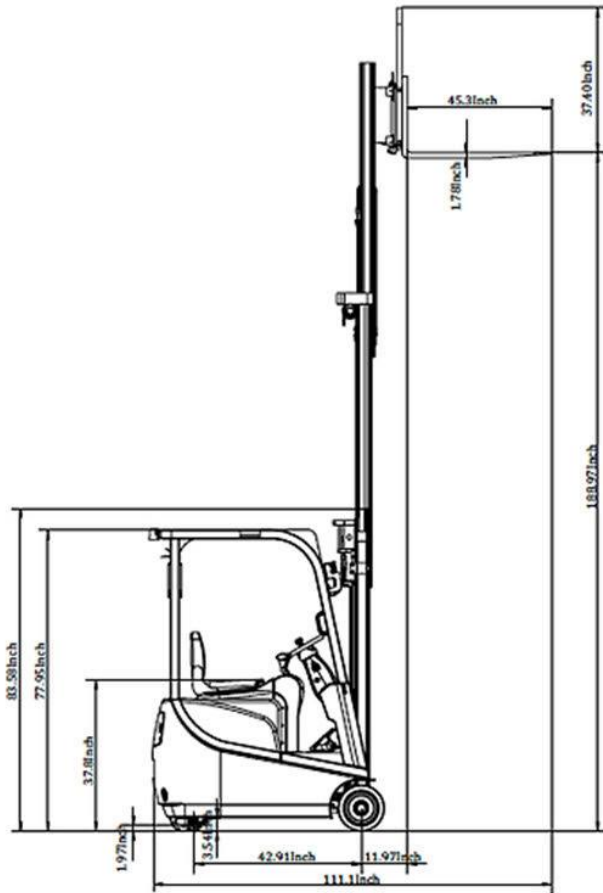

MODEL #	MAST	LIFT HEIGHT	MAX MAST HEIGHT	TOTAL LENGTH	SERVICE WEIGHT
EK15A-189Li	83.54"	189"	226.34"	111.1"	5560 lbs.