

EK18RR Stand-up Rider Reach Truck



Model		EK18RR
Lift		Electric
Drive		Electric
Load capacity	(lb.)	4000
Load center distance	(in)	24
Lifting height	(in)	275
Side Shifting Forks		3 Way Valve
Free Lift	(in)	79.92
Lowered mast height	(in)	123.27
Overall length/Extended	(in)	102.28
Overall width	(in)	54.72
Fork size, Thick/Width/Length	(in)	1.58/4.72/45
Fork adjust width	(in)	35.04
Reach Distance	(in)	22.44
Turning radius	(in)	75
Charger	(V/A)	48V/65A
Driving Motor	(V/W)	48V/6000
EPS Steering Motor	(V/W)	Yes
Lifting Motor	(V/W)	48V/11000
Battery voltage	(V/Ah)	48V/420Ah
Service Weight	(lb.)	9330

The EKKO EK18RR Stand-Up Reach Truck is ideal and designed for narrow aisles with the combination of the versatility of a forklift, reach truck and a walkie stacker. It is ideal for loading and unloading trucks, loading docks, stock rooms, manufacturing floors and warehousing.

Made from high quality steel and components with durable quality drives to withstand any terrain, usage, impact and directional changes for the use of any application with confidence and assurance.

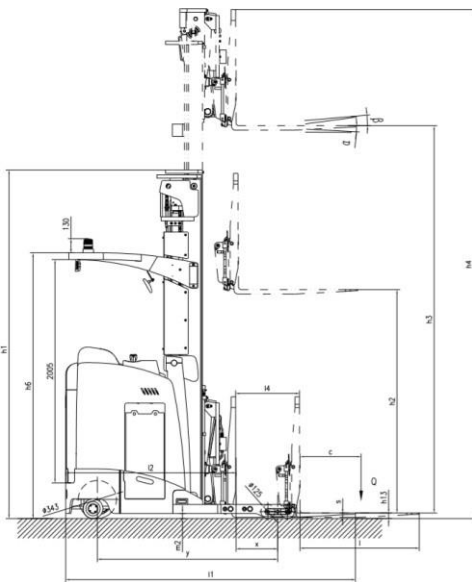

- Load Capacity 4000 lb.
- Side Shifting
- Raised Height 275" (14.75ft)
- Reach Distance of 19.7"
- Free Lift 63"
- Tilt 3/5 Degree
- Adjustable Forks 7.9-33"
- Fork Length 45.3"
- Curtis Instrument Controllers
- EPS (Electronic Power Steering)
- 48V German AC Drive Motor
- 48V Lift Motor
- Battery 48V/420Ah
- Polyurethane Wheels
- Ergonomic Handle and Controls
- Steel Construction
- Robotic Welding
- Charger 48V/65A
- 3 Year Limited Warranty

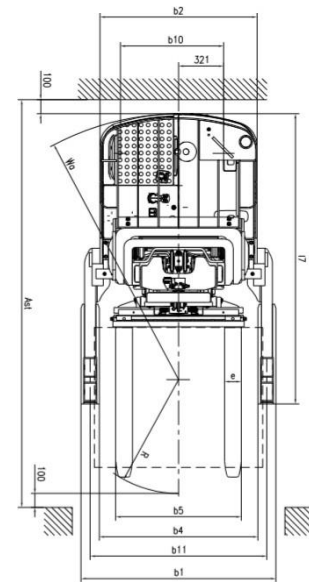

EKKO[®]

MATERIAL HANDLING EQUIPMENT

MOVING AHEAD

STAND-UP RIDER REACH TRUCK EK18RR SERIES

- Load Capacity 4500 lbs.
- Lift Height 196-275 in. 3 Stage
- Side Shifting Forks
- 48V/420Ah Industrial Battery
- Free Lift 53-79"
- Hydraulic Power Steering
- Length 102"
- Curtis Controller
- Tilt 3/6 degree
- Mast Height 96-123"
- Overhead Guard 78.93"
- Battery & Charger
- 3 Year Limited Warranty



EK18RR

Superior quality, maneuverable, compact, and durable for all your material handling applications. Ideal for small aisles and areas.

WEIGHT CAPACITY: 4000 lbs. @ 24" load center

LIFT HEIGHT: 196-275 3 Stage

SIDE SHIFTING FORKS: 45.3"

MAST HEIGHT: 96-123"

TURNING RADIUS: 75"

FREE LIFT: 53-79"

TILT: 2/4 degree

INDUSTRIAL BATTERY / CHARGER: 48V 420Ah, Industrial battery with external direct connect 210A 210VAC plug-in automatic 48V/65A charger (both Included)

BRAKING: Electromagnetic

SPEED TRAVEL: 5.9 mph empty ; 5.59 mph loaded

LIFTING SPEED: 9.05" ips empty; 7.48" ips loaded

LOWERING SPEED: 11.81" ips empty; 9.05" ips loaded

FRONT WHEELS: Polyurethane

REAR WHEELS: Polyurethane

HYDRAULICS LIFTING MOTOR: 48V 11000 Watt lifting motor with hardened chrome moly steel for durability.

DRIVE MOTOR: 48V 6000-Watt ZF AC drive motor for efficiency and high torque.

AC CONTROLLER: 48V Curtis provides performance through entire range of speed; Constant travel speed regardless of load; Battery discharge indicator combination gauge.

BRAKES: Drum Brakes with Electro-magnetic braking for secure stopping power

LIGHTING: LED Head lights, turn signals and brake lights.

OPERATOR CONTROLS: Tilt, lifting, lowering, side shifting forks, horn functions are located in the ergonomic Operators Compartment; Led lighting.

CHASSIS AND MAST: Robotic Welding; Heavy duty steel chassis with I-beam mast for durability; Telescoping mast.



RIDER REACH TRUCK



Model		EK18RR	EK18RRL
Power unit		Electric	Electric
Operation Type		Stand	Stand
Loading capacity	Q (LBS)	4000	4000
Load center	c (Inch)	19.7	19.7
Axle centre to fork face	x (Inch)	14.65	14.76
Wheelbase	y (Inch)	63.62	63.7
Service weight with battery	LBS	9330	9000
Wheels type		PU	PU
Driving wheel size	Φxw(Inch)	Φ13.5x5.2	Φ13.5x5.2
Bearing wheel size	Φxw(Inch)	Φ4.9x3.2	Φ4.9x3.2
Wheels, number front/rear (x = driven)		1x,2/4	1x,2/4
Track width	b ₁₀ (Inch)	28.9	28.9
Track width	b ₁₁ (Inch)	49.6	49.6
Mast/fork carriage tilt, forward/backward	a/b (°)	2/4	2/4
Lowered mast height	h ₁ (Inch)	123.27	96.42
Free lift height	h ₂ (Inch)	79.92	53.15
Lift height	h ₃ (Inch)	275.59	196.85
Extended mast height	h ₄ (Inch)	318.9	240.94
Height of overhead guard (cabin)	h ₆ (Inch)	93.94	93.94
Lowered fork height	h ₁₃ (Inch)	1.97	1.97
Overall length	l ₁ (Inch)	102.28	102.28
Length to fork face	l ₂ (Inch)	60.16	60.16
Overall width	b ₁ / b ₂ (Inch)	54.72/44.1	54.72/44.1
Fork dimensions	s/e/l (Inch)	1.58/4.72/45	1.58/4.72/45
Width of forks	b ₅ (Inch)	35.04	35.04
Distance Between Support arms/loading surfaces	b ₄ (Inch)	44.49	44.49
Reach distance	l ₄ (Inch)	22.44	22.44
Min.Ground clearance	m ₂ (Inch)	1.81	1.81
Aisle width with pallet 1000 x 1200 across forks	Ast (Inch)	116.93	116.93
Aisle width with pallet 800 x 1200 along forks	Ast (Inch)	118.9	118.9
Min.Turning radius	Wa (Inch)	75	75
length across wheel arms	l ₇ (Inch)	81.65	81.65
Travel speed,laden/unladen	Mph	5.59/5.90	5.59/5.90
Lifting speed, with/without load	(in/s)	7.48/9.05	7.48/9.05
Lowering speed, with/without load	(in/s)	11.81/9.05	11.81/9.05
Reach speed,laden/unladen	(in/s)	3.93/4.33	3.93/4.33
Maximum climbing ability, with/without load	(%)	6/10	6/10
Electromagnetic + mechanical		Electromagnetic	Electromagnetic
Drive motor, 60-minute rating	Watts	6000	6000
Lift motor rating at S3 15%	Watts	11000	11000
Battery according to DIN 43531/35/36 A,B,C,no		no	no
Battery voltage/rated capacity	(V/Ah)	48/420	48/420
Battery weight (± 5%)	(LBS)	1585	1585
Type of drive control		AC	AC
Noise level at operator's ear	(dB(A))	≤75	≤75

