

EK30SLP Liquid Propane Forklift

Model		EK30SLP
Lift		Propane
Drive		Sit-Down
Load capacity	(lb.)	6000
Load center distance	(in)	24
Tire	(in)	Solid Pneumatic
Lifting height	(in)	189
Free lifting height	(in)	40.9
Lowered mast height	(in)	89.4
Mast tilting angle (front / rear)	(°)	6/12
Service Brake		Hydraulic Floor Pedal
Overall length	(in)	150.3
Overall width	(in)	48.2
Fork size, Thick/Width/Length	(in)	42.1X4.9X1.77
Wheelbase	(in)	69
Min turning radius (exterior)	(in)	94.5
Driving speed, load/unload	Mph	11.8/11.8
Engine Mode		Kubota WG2503
Engine rated power	HP/rpm	LPG: 58.3/2600
Service Weight	(lb.)	10,320

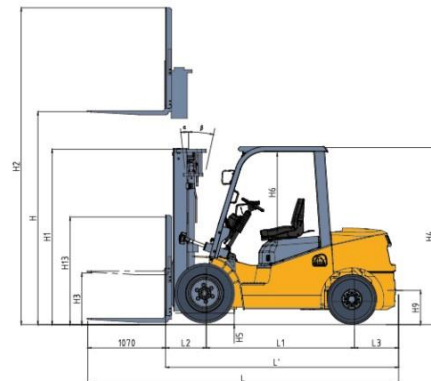
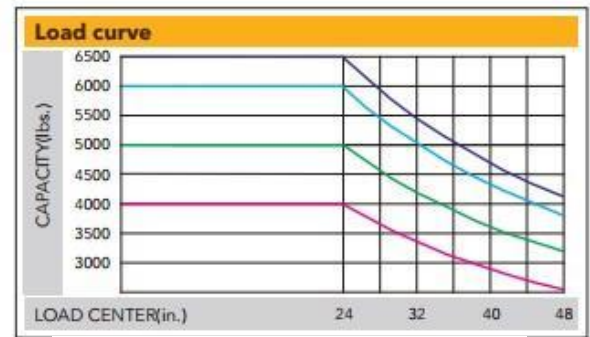

Features Pattern Cushion Tires that are perfect for use indoors OR outdoors

The EKKO EK30SLP Liquid Propane 4 Wheel Forklift is designed to be used for all your material handling demands, warehousing, and distribution.

This unit is manufactured with high durable quality, Tier 4 EPA compliant with the PSI engine and competitive pricing.

- The operation space is enlarged by heightened overhead guard and using large arc shape of the overhead guard's front leg.
- Semi-suspension seat, and small steering wheel, electro-hydraulic direction changing, and automobile type double combined switch effectively improve driving comfort level.
- Cushion connection and whole suspension cab can absorb the vibrations of truck effectively.
- Lowering damping device inside the lifting system reduces mast's shock and vibration, avoiding noise caused by goods falling to the ground.
- Small turning radius makes steering flexible and easy.
- with optimized hydraulic system, the truck is more energy-efficient and has lower fuel consumption.
- The engine satisfies the CARB 4 regulation.

