

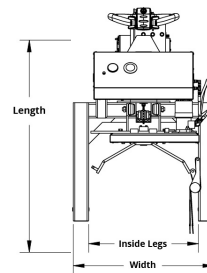

Strap Connection
Counterweighted

Grip Connection
Counterweighted

- Powered lifting, rotating, and driving (up to 2.5 MPH).
- Quickly and ergonomically transport, dump and store drums (steel, plastic and fiber).
- Rotate 360° continuously in either direction, at 6 RPM.
- Grip: remote jaws grab drums 18-24" in diameter, with adjustable pressure gauge.
- Straps: secures drums manually, 14-24" in diameter
- Straddle: extended legs go under pallets, shelving, or on outside of drums.
- Counterweighted: ability to butt directly up to pallets, shelving, or other items.
- Standalone unit (no forklift required).
- Heavy gauge steel construction.
- Optional floor lock available (sold separately).
- Premium powder coat paint finish.
- Ships fully assembled, ready to use.
- Made in the U.S.A.

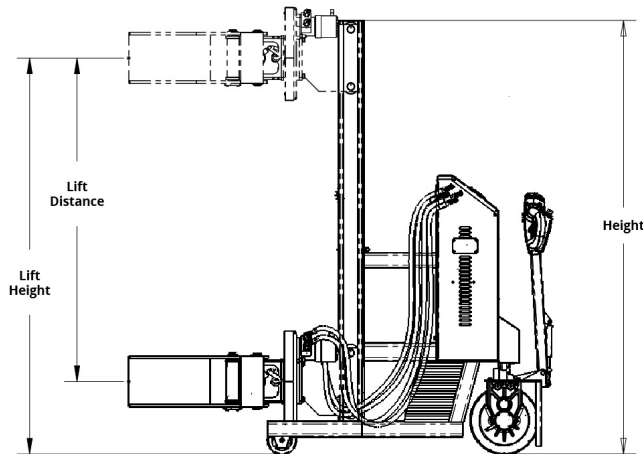

Straddle

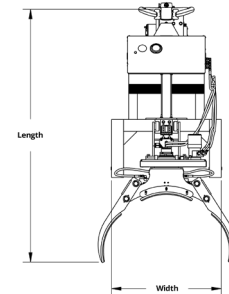

Counterweighted

Fully Powered Drum Lift and Rotators

Model #	Connection Type	Base	Height	Lift		Power Source	Turn Radius	Inside Legs	Casters	Dimensions L x W x H	Capacity (lbs.)	Weight (lbs.)
				Ht.	Dist.							
F89838A2	Strap Connection	Straddle	78"	71"	58"	24V Battery	40"	25"	(2) 5" Front Rigid, (1) 12" Rear Powered Wheel	47 x 32 x 78"	1,000	725
F89837A1			90"	84"	71"		39"	-		53 x 32 x 90"		760
F89832A5		Counter-weighted	78"	71"	58"		47"	25"		47 x 32 x 78"		1,265
F89831A4			90"	84"	71"		41"	-		53 x 32 x 90"		1,300
F80144A7	Grip Connection	Straddle	78"	71"	58"		47"	25"		61 x 32 x 78"		1,000
F80143A6			90"	84"	71"		41"	-		73 x 32 x 90"		1,035
F80146A9		Counter-weighted	78"	71"	58"		41"	-		61 x 32 x 78"		1,560
F80145A8			90"	84"	71"		41"	-		73 x 32 x 90"		1,595

Straddle Floor Lock: Model # F89410A2, optional floor lock for straddle models

Counterweighted Floor Lock: Model # F89413A9, optional floor lock for counterweighted models

