

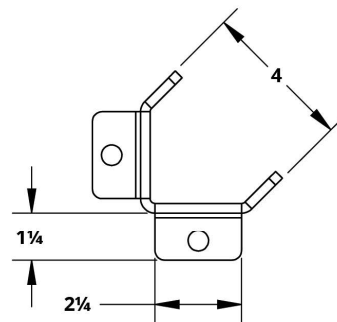

- Perfect solution for protecting posts, products, equipment, and employees.
- Prevent unexpected damage to racking and shelving from forklifts or pallet jacks.
- Eliminate accidental denting or marring.
- ¼" Heavy duty steel, virtually indestructible.
- Compatible with posts 3½" or less in diameter.
- Predrilled holes to secure unit to floor, installation hardware included.
- Premium powder coat paint finish.
- Ships fully assembled, ready to use.
- Made in the U.S.A.

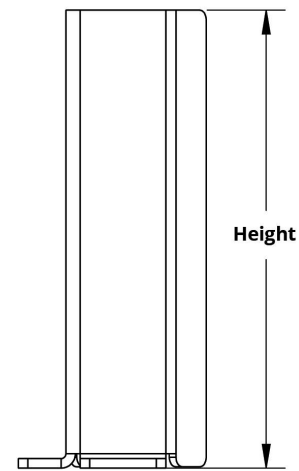

Post Protectors

Model #	Height	Dimensions W x H	Steel Gauge	Weight (lbs.)
F85061A2	12"	4 x 12"	3	8
F85060A3	18"	4 x 18"		10
F85062A1	24"	4 x 24"		12