

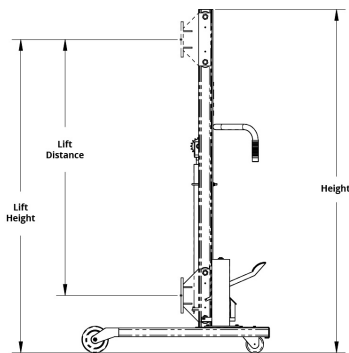

- Solves a variety of material handling needs with one base unit.
- Base unit works with a variety of optional attachments.
- Platforms, forks, and drum attachments available: interchangeable.
- Ergonomically lift and/or rotate a variety of material.
- Easily maneuver supplies throughout your facilities.
- Lift up to 84" in less than 30 seconds.
- Standalone unit (no forklift required).
- Fully powered options have up to 2.5 MPH of drive speed.
- Fully and Semi-Powered units have a lift speed of 3.4" per second.
- Heavy gauge steel construction.
- Premium powder coat paint finish.
- Ships fully assembled, ready to use.
- Made in the U.S.A.

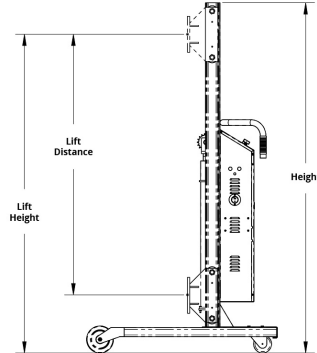

Manual



Semi-powered

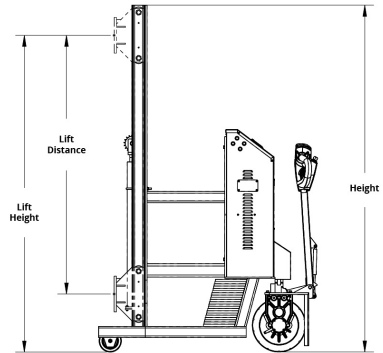

Fully Powered

Steel Lift Universal Lifts & Stackers

Model #	Style	Base	Lift			Power Source		Wheels	Dimensions L x W x H	Capacity (lbs.)	Weight (lbs.)			
			Height	Distance	Drive	Lift								
F88567B5	Manual	Straddle	78"	71"	58"	Manual	Manual	(2) 6" Wheels & (2) 4" Casters: 2 Rigid, 2 Swivel	43 x 30 x 78"	800	355			
F88568B4			90"	84"	71"				43 x 30 x 90"		380			
F88553C1	Semi-powered		78"	71"	58"				Manual		12V Battery	43 x 30 x 78"	465	
F88561C1			90"	84"	71"							43 x 30 x 90"	490	
F87022B6			78"	71"	58"							Pneumatic	43 x 30 x 78"	355
F87040B4			90"	84"	71"								43 x 30 x 90"	380
F80136A9	Fully Powered	Counter- weighted	78"	71"	58"	24V Battery	24V Battery	(2) 5" Front & (1) 12" Power: 2 Rigid, 1 Power	47 x 32 x 78"	1,000	1,130			
F80135A8			90"	84"	71"				47 x 32 x 90"		1,165			

