

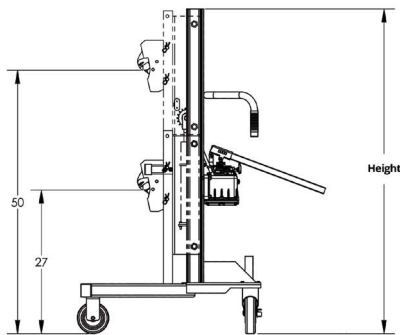

- Ideal for picking drums from pallets or spill containment platforms.
- Safely and ergonomically lift and maneuver drums throughout facility.
- Reduce worker fatigue or possible injury.
- 3 Attachment options available: beak, straps, or cylinder.
- Hand operated hydraulic hand pump..
- Single mast design for maximum visibility
- Backplate makes attachments interchangeable (additional attachments sold separately).
- Heavy gauge steel construction.
- Premium powder coat paint finish.
- Ships fully assembled, ready to use.
- Made in the U.S.A.

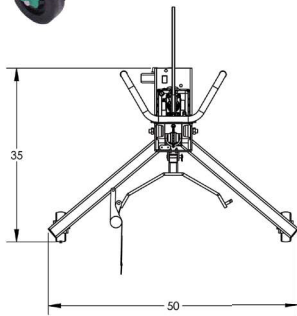

**Beak**  
Spring-loaded, hands-free chime hook for drums

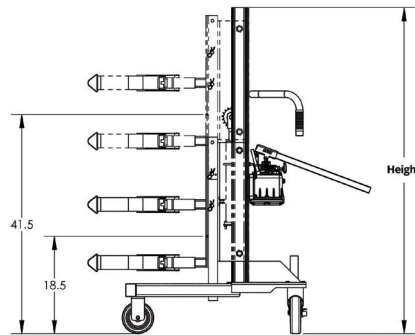

**Strap**  
Dual ratchet straps for securing drums

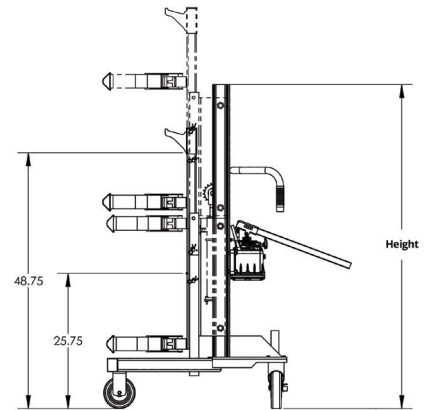

**Cylinder**  
Expanded cradle with dual ratchet straps for cylinders and other tall containers

## Raptor - Drum Lift and Transporters

| Model #  | Attachment | Drum Capability |          |          | Handle/Pump | Wheels                                  | Dimensions W x D x H | Capacity (lbs.) | Weight (lbs.) |
|----------|------------|-----------------|----------|----------|-------------|---|----------------------|-----------------|---------------|
|          |            | Type            | Gallons  | Diameter |             |   |                      |                 |               |
| F88575C5 | Beak       | Universal       | 30/55    | -        | Hand Pump   | (2) 6" Front Rigid & (1) 8" Rear Swivel | 50 x 35 x 62"        | 1,000           | 235           |
| F88577B3 | Strap      |                 | 30/55/85 | 14 - 28" |             |   |                      |                 | 255           |
| F88576B4 | Cylinder   | Cylinder        | -        | 9 - 18"  |             |   |                      |                 | 240           |

**Additional Attachments:** F69471A7 Beak, F64657A7 Strap, F69282A7 Cylinder

