

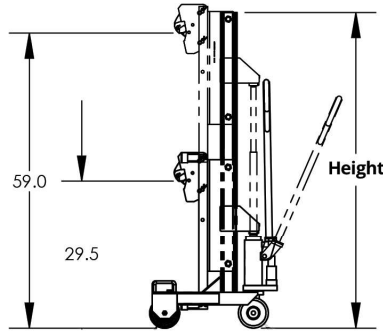

- Ideal for picking drums from pallets or spill containment platforms.
- Safely and ergonomically lift and maneuver drums throughout facility.
- Easy to use tiller style hand pump.
- Telescoping legs for a smaller footprint and improved stability.
- Reduce worker fatigue or possible injury.
- 3 Attachment options available: beak, straps, or cylinder.
- Hand operated hydraulic pump/lift.
- Single mast design for maximum visibility
- Backplate makes attachments interchangeable (additional attachments sold separately).
- Heavy duty wheels create easy mobility for heavy loads.
- Heavy gauge steel construction.
- Premium powder coat paint finish.
- Ships fully assembled, ready to use.
- Made in the U.S.A.

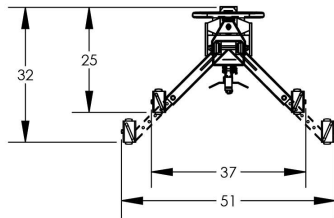

**Beak**  
Spring-loaded, hands-free  
chime hook for drums

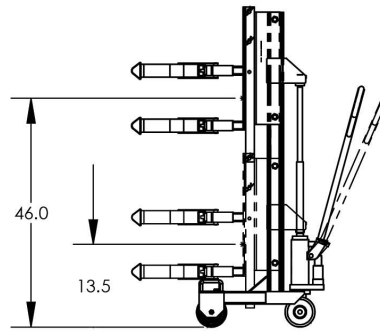

**Strap**  
Dual ratchet straps  
for securing drums

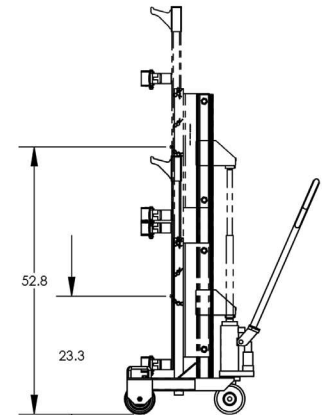

**Cylinder**  
Expanded cradle with dual  
ratchet straps for cylinders  
and other tall containers

## Barrel Hawk - Drum Lift and Transporters

Model #	Attachment	Drum Capability			Handle/ Pump	Wheels	Dimensions W x D x H	Capacity (lbs.)	Weight (lbs.)
		Type	Gallons	Diameter					
F89265	Beak	Universal	30/55	-	Pallet Jack Style	(2) 6" Front Rigid & (2) 6" Rear Swivel	(37-51) x (25-32) x 63"	1,000	245
F89264	Strap		30/55/85	14 - 28"					265
F89263	Cylinder	Cylinder	-	9 - 18"					250

**Additional Attachments:** F69471A7 Beak, F64657A7 Strap, F69282A7 Cylinder

