

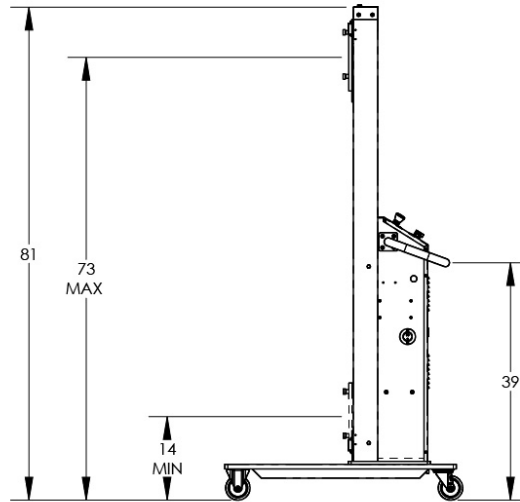

**Narrow
Platform
End**

- Lightweight, spark resistant, and versatile handling.
- Base unit works with a variety of optional attachments.
- Spindle/mandrel and platform attachments available: interchangeable.
- Ergonomically lift and maneuver a variety of material.
- Easily transport supplies throughout your facilities.
- Lift up to 73" in less than 30 seconds.
- 500 lb. capacity.
- Standalone unit (no forklift required).
- Premium aluminum construction.
- Ships fully assembled, ready to use.
- Made in the U.S.A.

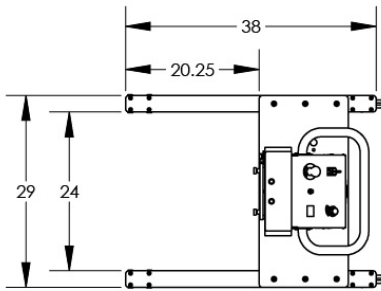

Aluminum Lift Universal Lift & Stacker

Model #	Style	Base	Height	Lift		Power Source		Casters	Dimensions L x W x H	Capacity (lbs.)	Weight (lbs.)
				Height	Distance	Drive	Lift				
F89398	Semi-Powered	Straddle	81"	73"	59"	Manual	24V Battery	(4) 4" Polyolefin: 2 Rigid, 2 Swivel	38 x 29 x 81"	500	225

Aluminum Lift Accessories

Description	Model #	Size L x W	Capacity (lbs.)	Weight (lbs.)
Mandrel End	F80106A8	21½"	500	9
Wide Platform End	F89354	16¾ x 20"	500	16
Narrow Platform End	F89390	26 x 13"	400	18



Wide Platform End



Mandrel End

